

Inhoudsopgave

Drijfwerkhuis 02	24
Kappen 04	10
Koppeling 03	18
Remmen 01	82
Schakelpoken 04	78
Stickers 01	96
Stuur & Kabels 04	66
Stuurboom 03	48
Tandwielen 02	34
Type Stickers 02	92
Wielas 01	40
Wielen & Banden 03	84
Parts Index	98

Code	Description	Notes
001_1_12621	001_01 - BODYGUARD	Version: MF 530, MF 520
001_2_12649	001_02 - BODYGUARD	Version: MF 510, MF 530, MF 520, MF 500
001_3_12676	001_03 - BODYGUARD	
001_4_12698	001_04 - BODYGUARD	
002_0_12722	002_00 - SELF-VENTILATING CONE CLUTCH	
002_1_12741	002_01 - SELF-VENTILATING CONE CLUTCH	
002_2_12761	002_02 - SELF-VENTILATING CONE CLUTCH	
002_3_12779	002_03 - SELF-VENTILATING CONE CLUTCH	
003_0_12805	003_00 - GEARBOX	
003_1_12834	003_01 - GEARBOX (500-520/30-530S/S2)	
003_2_12864	003_02 - GEARBOX (500-520-530)	
004_0_12893	004_00 - GEARS	
004_1_12930	004_01 - GEARS	Version: MF 530, MF 500, MF 520
004_2_12967	004_02 - GEARS (500-520/30-530S/S2)	
006_0_13060	006_00 - DIFFERENTIAL (530)	
006_1_13089	006_01 - DIFFERENTIAL (530)	
007_0_13116	007_00 - STEERING COLUMN	
007_1_13140	007_01 - STEERING COLUMN	Version: MF 520, MF 530
007_2_13157	007_02 - STEERING COLUMN	Version: MF 530, MF 520, MF 500
007_3_13177	007_03 - STEERING COLUMN (500/10/20/30-530S/S2)	
008_0_13197	008_00 - HANDLEBAR	
008_1_13255	008_01 - HANDLEBAR	Version: MF 520, MF 530, MF 500
008_2_13308	008_02 - HANDLEBAR	
008_3_13362	008_03 - HANDLEBAR (500-510-520-530)	
008_4_13416	008_04 - HANDLEBAR (500-510-520-530)	
009_0_13470	009_00 -CONTROLS	
009_1_13502	009_01 - CONTROLS	Version: MF 500, MF 520, MF 530
009_2_13534	009_02 - CONTROLS (500-510-520-530)	Version: MF 510, MF 530, MF 520, MF 500
009_3_13564	009_03 - CONTROLS(500/10/20/30-530S/S2)	
009_4_13594	009_04 - CONTROLS(500/10/20-530-530S2)	
010_0_13623	010_00 - BRAKES	
010_1_13645	010_01 - BRAKES	
011_3_13744	W011_03 - HEELS	
012_0_13785	012_00 - STICKERS	

Motor mower 530

Code	Description	Notes
012_1_13807	012_01 - STICKERS	
012_2_13824	012_02 - STICKERS	
013_0_13845	013_00 - STICKERS	
013_1_13860	013_01 - STICKERS	

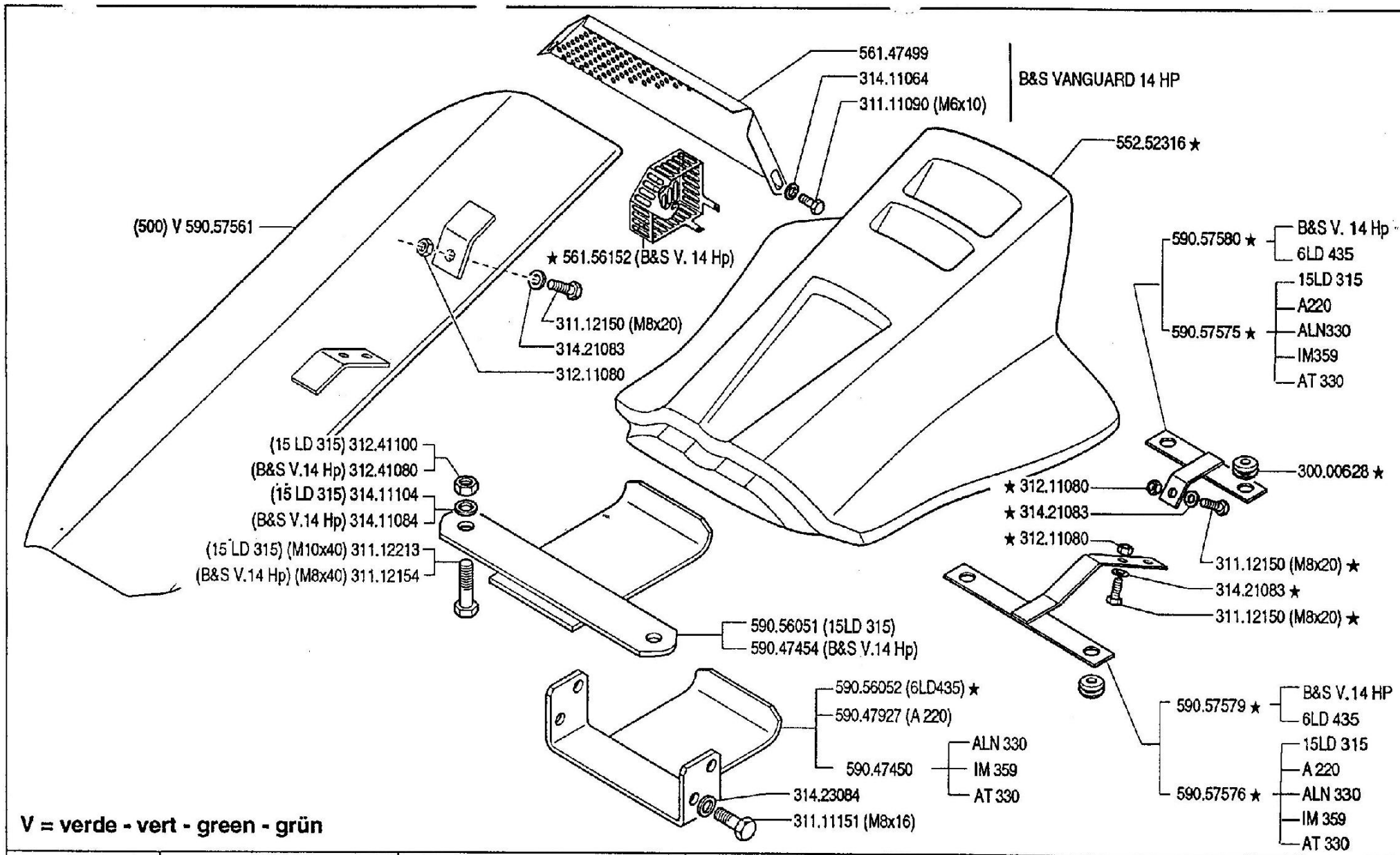

	500 serie 95	CARROZZERIA (500 - 520 - 530)		DALLA MACCHINA DE LA MAQUINA DE LA MACHINE FROM THE MACHINE AB DER MASCHINE	01.01
		CARROCERIA CARROSSERIE	BODY KAROSSERIE		

★ N.

Pos.	Code	Q.ty	Description	Notes
30000628	30000628	0	CABLE GLAND 90/200/30	
31111090	31111090	0	SCREW TE M5X10 UNI 5739 8G	
31111151	31111151	0	SCREW TE M8X16 UNI 5739 8G	
31112150	31112150	0	SCREW TE M8X20 UNI 5739 8G	
31112154	31112154	0	SCREW TE M8X40 UNI 5739 8G	
31112213	31112213	0	SCREW TE M10X40 UNI 5739	
31211080	31211080	0	NUT M8	
31241080	31241080	0	HEXAGON SELFLOCK NUT M8	
31241100	31241100	0	SELFLOCK HEXAGON NUT M10	
31411064	31411064	0	WASHER 6,4x12,5	
31411084	31411084	0	WASHER 8,4x17	
31411104	31411104	0	WASHER 10,5x18	
31421083	31421083	0	WASHER	
31423084	31423084	0	SPRING WASHER 8,4	
55252316	55252316	0	BODYWORK	
56147499	56147499	0	GUARD	
56156152	56156152	0	GUARD	
59047450	59047450	0	SHIELD	
59047454	59047454	0	SHIELD	
59047927	59047927	0	SHIELD	
59056051	59056051	0	SHIELD	
59056052	59056052	0	SHIELD	
59057561	59057561	0	SHIELD	
59057575	59057575	0	HOLDER	
59057576	59057576	0	HOLDER	
59057579	59057579	0	HOLDER	
59057580	59057580	0	HOLDER	

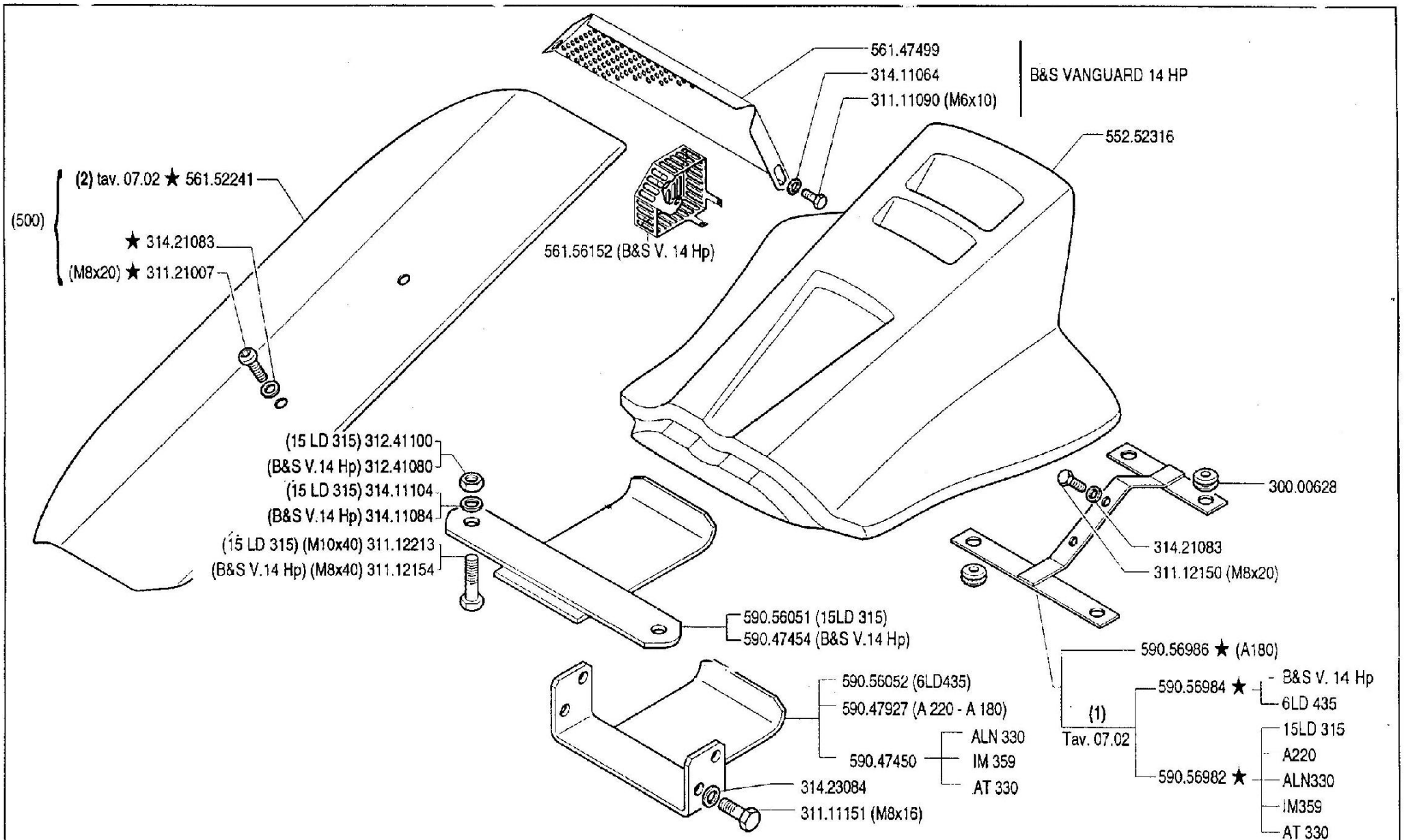

	<h1>500</h1> serie 95	CARROZZERIA (500 - 510 - 520 - 530)		DALLA MACCHINA DE LA MAQUINA DE LA MACHINE FROM THE MACHINE AB DER MASCHINE ★ N.		<h1>01.02</h1>
		CARROCERIA	BODY		22690 (530)	
		CARROSSERIE	KAROSSERIE		158933 (520)	
					★ (510)	
					80952 (500)	9/1997

Pos.	Code	Q.ty	Description	Notes
30000628	30000628	0	CABLE GLAND 90/200/30	
31111090	31111090	0	SCREW TE M5X10 UNI 5739 8G	
31111151	31111151	0	SCREW TE M8X16 UNI 5739 8G	
31112150	31112150	0	SCREW TE M8X20 UNI 5739 8G	
31112154	31112154	0	SCREW TE M8X40 UNI 5739 8G	
31112213	31112213	0	SCREW TE M10X40 UNI 5739	
31121007	31121007	0	SCREW BCEI M8X20 ISO7380	
31241080	31241080	0	HEXAGON SELFLOCK NUT M8	
31241100	31241100	0	SELFLOCK HEXAGON NUT M10	
31411064	31411064	0	WASHER 6,4x12,5	
31411084	31411084	0	WASHER 8,4x17	
31411104	31411104	0	WASHER 10,5x18	
31421083	31421083	0	WASHER	
31423084	31423084	0	SPRING WASHER 8,4	
55252316	55252316	0	BODYWORK	
56147499	56147499	0	GUARD	
56152241	56152241	0	CARROZZERIA MF LAT./97 *V*	
56156152	56156152	0	GUARD	
59047450	59047450	0	SHIELD	
59047454	59047454	0	SHIELD	
59047927	59047927	0	SHIELD	
59056051	59056051	0	SHIELD	
59056052	59056052	0	SHIELD	
59056982	59056982	0	HOLDER	
59056984	59056984	0	HOLDER	
59056986	59056986	0	HOLDER	

500

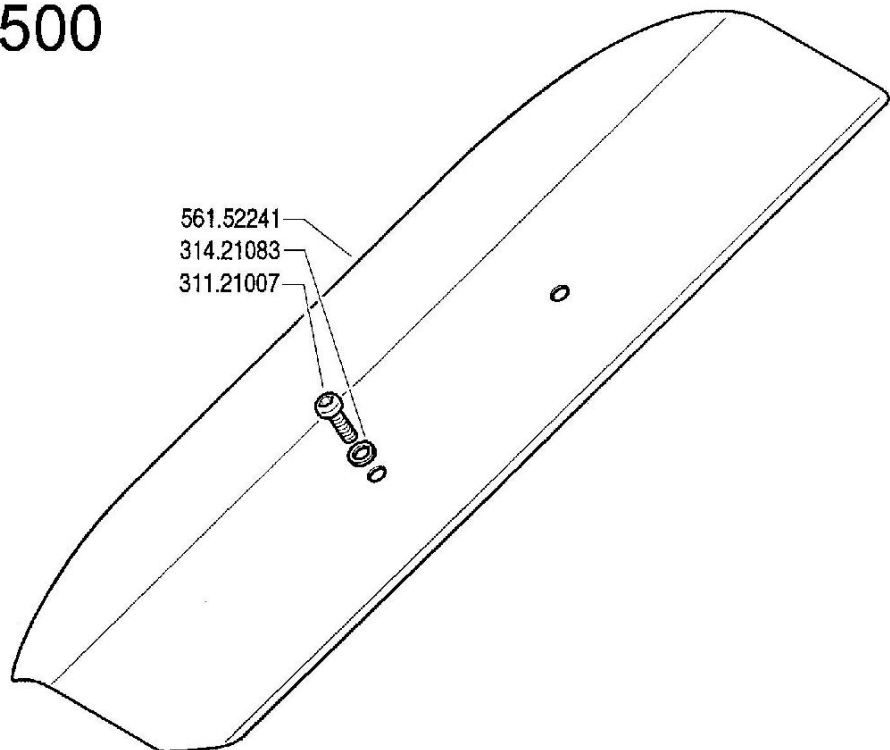

510 - 520 - 530

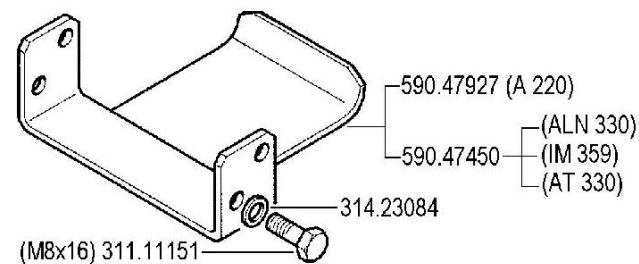
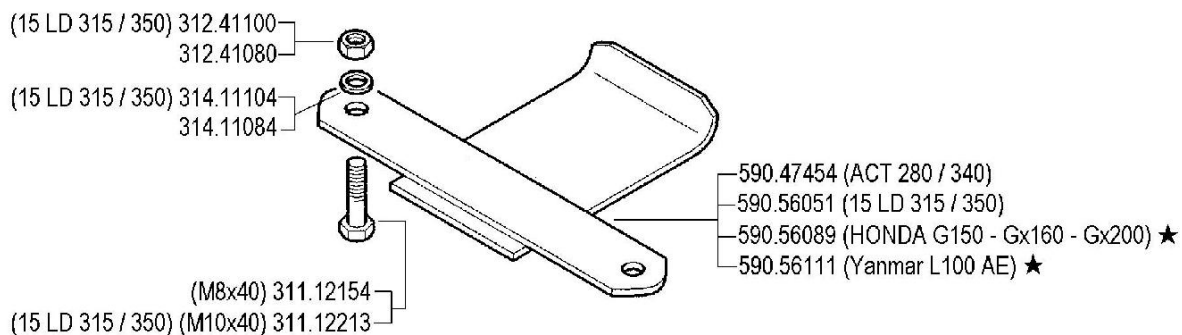
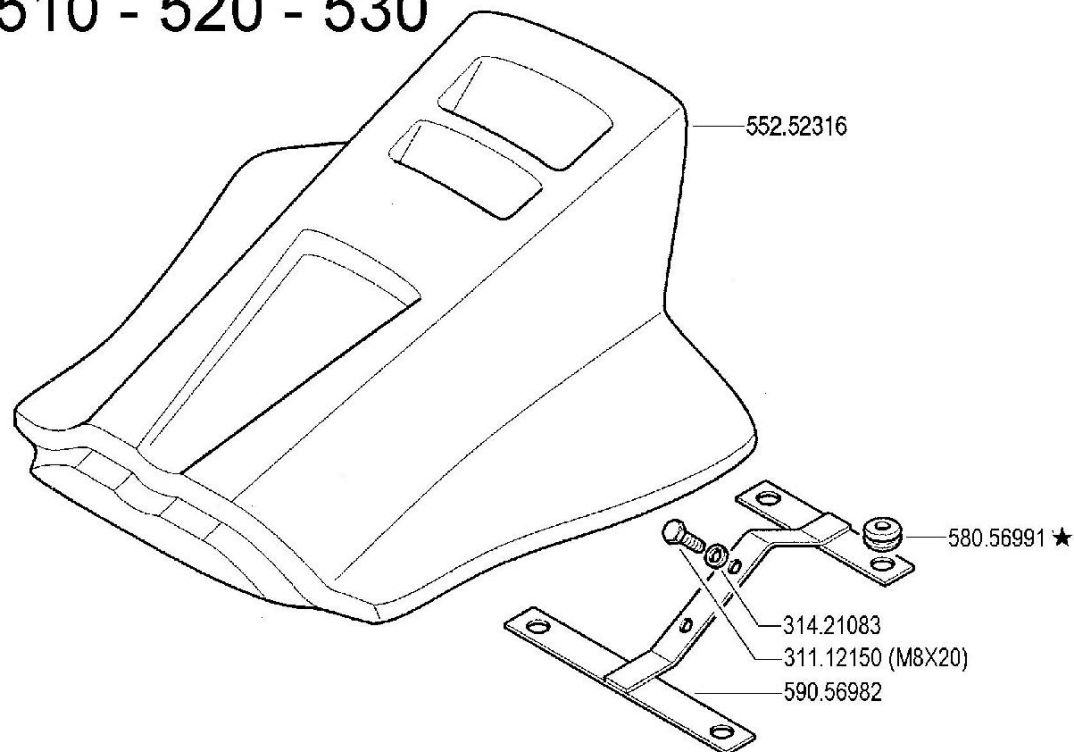

FERRARI

500 serie 95

BODY
CARROCERIA

CARROZZERIA

CARROSSERIE
KAROSSERIE

DALLA MACCHINA
DE LA MAQUINA
DE LA MACHINE
FROM THE MACHINE
AB DER MASCHINE

AGGIORNAMENTO

REVISION

MISE A JOUR

APLAZAMIENTO

ANPASSUNG

01 03

1/2000

★N.

Mod.

ZENIT

Pos.	Code	Q.ty	Description	Notes
31111151	31111151	0	SCREW TE M8X16 UNI 5739 8G	
31112150	31112150	0	SCREW TE M8X20 UNI 5739 8G	
31112154	31112154	0	SCREW TE M8X40 UNI 5739 8G	
31112213	31112213	0	SCREW TE M10X40 UNI 5739	
31121007	31121007	0	SCREW BCEI M8X20 ISO7380	
31241080	31241080	0	HEXAGON SELFLOCK NUT M8	
31241100	31241100	0	SELFLOCK HEXAGON NUT M10	
31411084	31411084	0	WASHER 8,4x17	
31411104	31411104	0	WASHER 10,5x18	
31421083	31421083	0	WASHER	
31423084	31423084	0	SPRING WASHER 8,4	
55252316	55252316	0	BODYWORK	
56152241	56152241	0	CARROZZERIA MF LAT./97 *V*	
58056991	58056991	0	CABLE GLAND	
59047450	59047450	0	SHIELD	
59047454	59047454	0	SHIELD	
59047927	59047927	0	SHIELD	
59056051	59056051	0	SHIELD	
59056089	59056089	0	SHIELD	
59056111	59056111	0	SHIELD	
59056982	59056982	0	HOLDER	

500

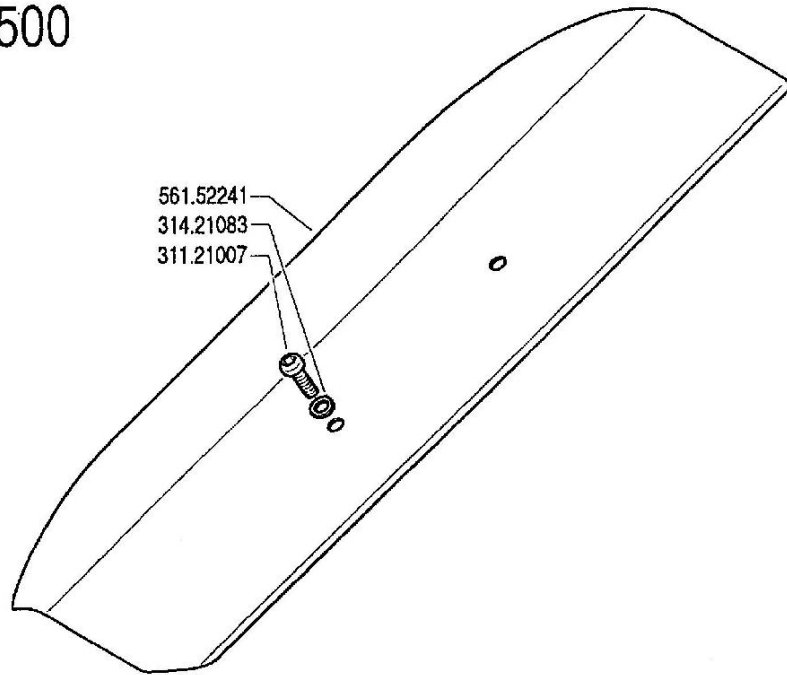

510 - 520 - 530 - 530S ★ - 530S2 ★

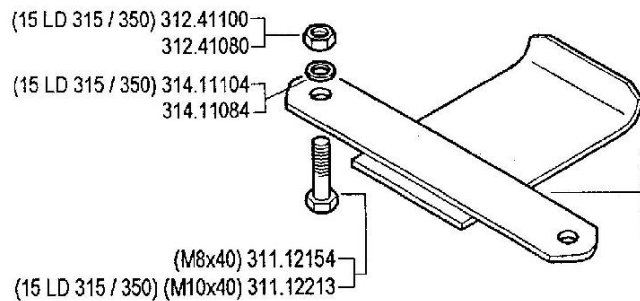
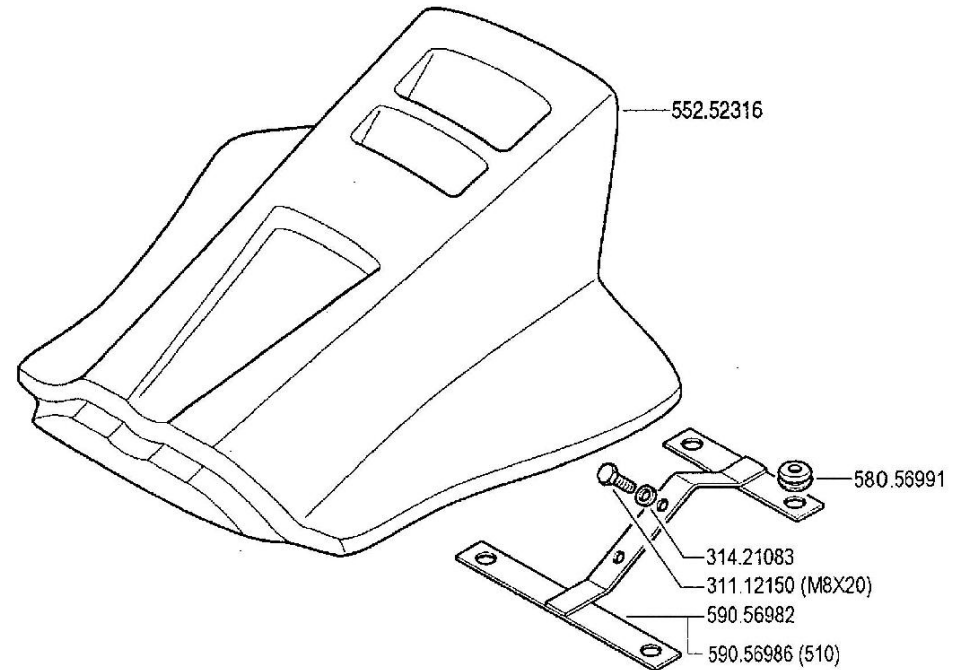

- 561.56119 ★ (ACT 280 / 340)
- 590.56051 (15 LD 315 / 350)
- 590.56089 (HONDA Gx120 ★ - Gx160 - Gx200)
- 590.56111 (Yanmar L100 AE)

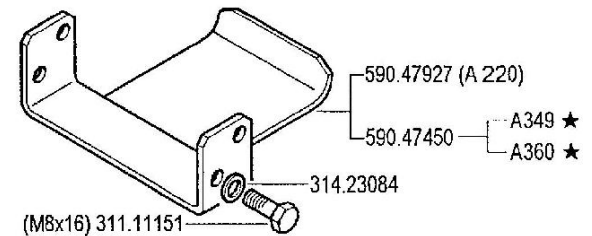
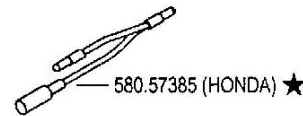

FERRARI

500 serie **95**

BODY
CARROCERIA

CARROZZERIA

CARROSSERIE
KAROSSERIE

DALLA MACCHINA
DE LA MAQUINA
DE LA MACHINE
FROM THE MACHINE
AB DER MASCHINE

★N.

AGGIORNAMENTO
REVISION
MISE A JOUR
APLAZAMIENTO
ANPASSUNG

01

Rev.
4

10/2001

ZENNE

Pos.	Code	Q.ty	Description	Notes
31111151	31111151	0	SCREW TE M8X16 UNI 5739 8G	
31112150	31112150	0	SCREW TE M8X20 UNI 5739 8G	
31112154	31112154	0	SCREW TE M8X40 UNI 5739 8G	
31112213	31112213	0	SCREW TE M10X40 UNI 5739	
31121007	31121007	0	SCREW BCEI M8X20 ISO7380	
31241080	31241080	0	HEXAGON SELFLOCK NUT M8	
31241100	31241100	0	SELFLOCK HEXAGON NUT M10	
31411084	31411084	0	WASHER 8,4x17	
31411104	31411104	0	WASHER 10,5x18	
31421083	31421083	0	WASHER	
31423084	31423084	0	SPRING WASHER 8,4	
55252316	55252316	0	BODYWORK	
56152241	56152241	0	CARROZZERIA MF LAT./97 *V*	
56156119	56156119	0	SHIELD	
58056991	58056991	0	CABLE GLAND	
58057385	58057385	0	LINE	
59047450	59047450	0	SHIELD	
59047927	59047927	0	SHIELD	
59056051	59056051	0	SHIELD	
59056089	59056089	0	SHIELD	
59056111	59056111	0	SHIELD	
59056982	59056982	0	HOLDER	
59056986	59056986	0	HOLDER	

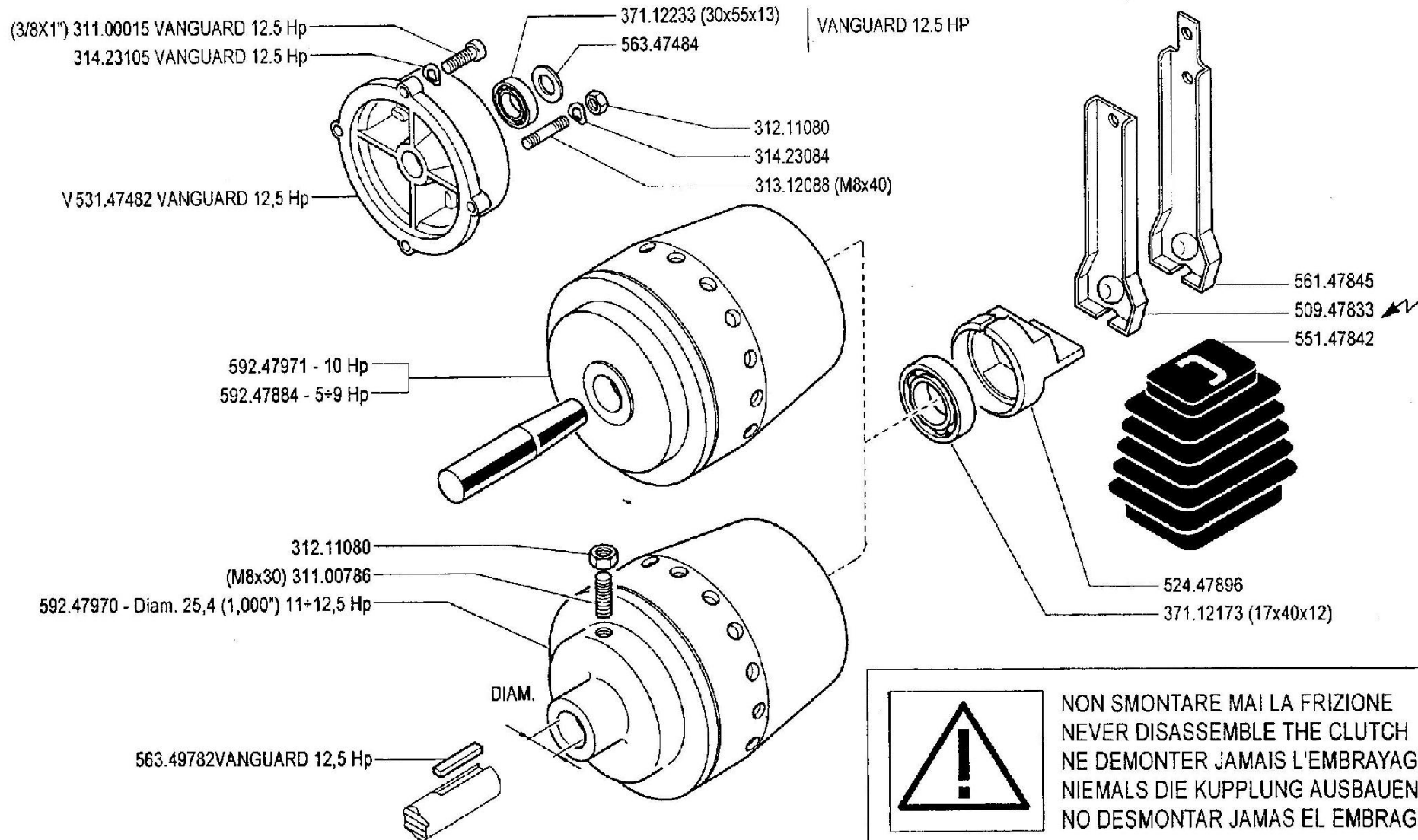

 NON SMONTARE MAI LA FRIZIONE
 NEVER DISASSEMBLE THE CLUTCH
 NE DEMONTER JAMAIS L'EMBRAYAGE
 NIEMALS DIE KUPPLUNG AUSBAUEN
 NO DESMONTAR JAMAS EL EMBRAGUE

V = verde - vert - green - grün

FERRARI

500 serie **95**

FRIZIONE A CONO AUTOVENTILANTE

EMBRAGUE
EMBRAYAGE

CLUTCH
KUPPLUNG

DALLA MACCHINA
DE LA MAQUINA
DE LA MACHINE
FROM THE MACHINE
AB DER MASCHINE

N.

02.00

01.06.1995

Pos.	Code	Q.ty	Description	Notes
31100015	31100015	0	SCREW TE 3/8X1	
31100786	31100786	0	SCREW STEI M8X30 UNI5923 8G	
31211080	31211080	0	NUT M8	
31312088	31312088	0	STUD BOLT M8X40X14X14	
31423084	31423084	0	SPRING WASHER 8,4	
31423105	31423105	0	SPRING WASHER 10,5	
37112173	37112173	0	BEARING	
37112233	37112233	0	BEARING	
50947833	50947833	0	CLUTCH LEVER	
52447896	52447896	0	PRESSURE PLATE	
53147482	53147482	0	ENGINE FLANGE	
55147842	55147842	0	BELLOWS	
56147845	56147845	0	CLUTCH LEVER	
56347484	56347484	0	SHIM	
56349782	56349782	0	DOWEL	
59247884	59247884	0	CLUTCH ASSY	
59247970	59247970	0	CLUTCH	
59247971	59247971	0	CLUTCH	

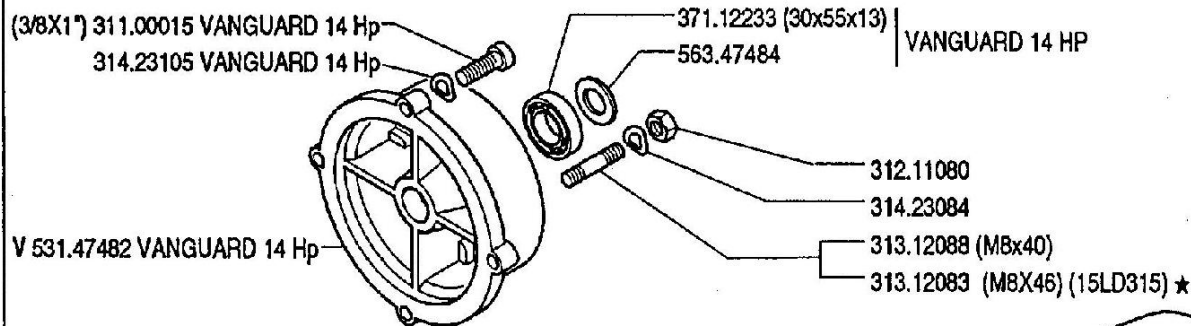

MOTORE ENGINE MOTEUR MOTOR	A	FRIZIONE EMBRAGUE EMBRAYAGE KUPPLUNG CLUTCH
Acme A220		592.47884
Acme ALN 330W		592.47884
Acme AT 330W		592.47971
Intermotor IM 359		592.47884
Briggs & Stratton Vanguard 14 Hp		592.47970
Lombardini 15 LD 315		592.47884
Lombardini 6 LD 435/400		592.47971

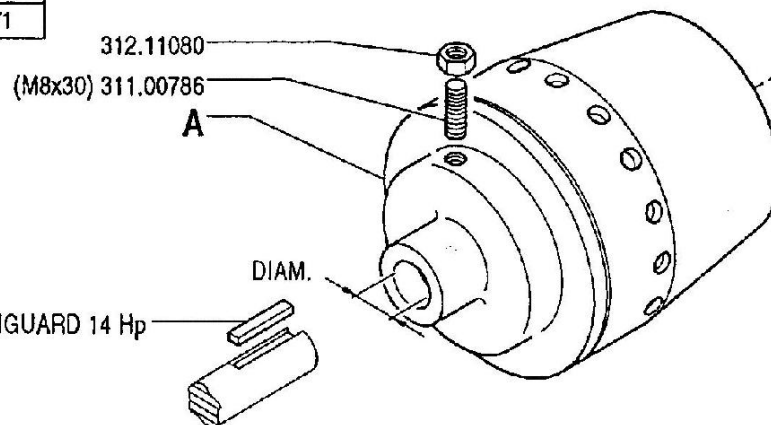
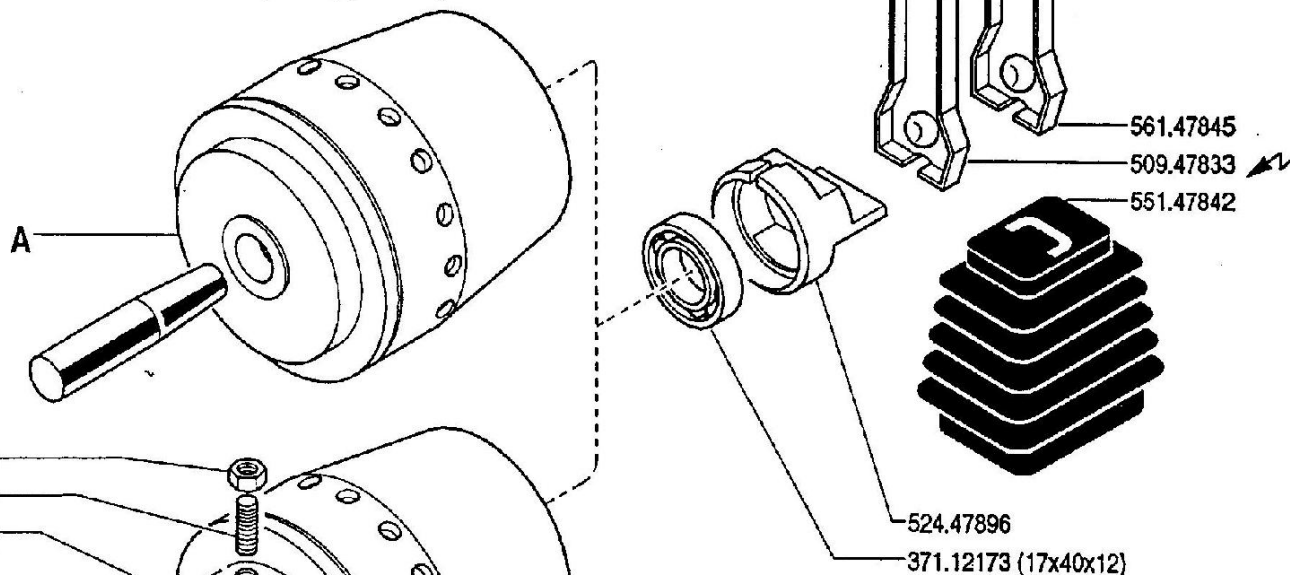

V = verde - vert - green - grün

NON SMONTARE MAI LA FRIZIONE
NEVER DISASSEMBLE THE CLUTCH
NE DEMONTER JAMAIS L'EMBRAYAGE
NIEMALS DIE KUPPLUNG AUSBAUEN
NO DESMONTAR JAMAS EL EMBRAGUE

FERRARI	500 serie 95	FRIZIONE A CONO AUTOVENTILANTE		DALLA MACCHINA DE LA MAQUINA DE LA MACHINE FROM THE MACHINE AB DER MASCHINE	AGGIORNAMENTO	02.01
		EMBRAGUE	CLUTCH		REVISION	
		EMBRAYAGE	KUPPLUNG		MISE A JOUR	
		★ N.	APLAZAMIENTO		02.09.1996	
					ANPASSUNG	

Pos.	Code	Q.ty	Description	Notes
31100015	31100015	0	SCREW TE 3/8X1	
31100786	31100786	0	SCREW STEI M8X30 UNI5923 8G	
31211080	31211080	0	NUT M8	
31312083	31312083	0	STUD BOLT M8X46X16X16	
31312088	31312088	0	STUD BOLT M8X40X14X14	
31423084	31423084	0	SPRING WASHER 8,4	
31423105	31423105	0	SPRING WASHER 10,5	
37112173	37112173	0	BEARING	
37112233	37112233	0	BEARING	
50947833	50947833	0	CLUTCH LEVER	
52447896	52447896	0	PRESSURE PLATE	
53147482	53147482	0	ENGINE FLANGE	
55147842	55147842	0	BELLOWS	
56147845	56147845	0	CLUTCH LEVER	
56347484	56347484	0	SHIM	
56349782	56349782	0	DOWEL	
59247884	59247884	0	CLUTCH ASSY	
59247970	59247970	0	CLUTCH	
59247971	59247971	0	CLUTCH	

★ (HONDA G150 - Gx160 - Gx200) 311.00003

371.12231 (HONDA G150 - Gx160 - Gx200) ★

563.56251 (HONDA G150 - Gx160 - Gx200) ★

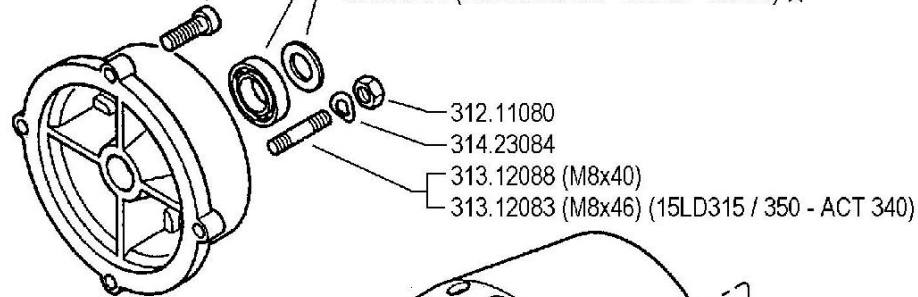

★ (HONDA G150 - Gx160 - Gx200) V 532.47468

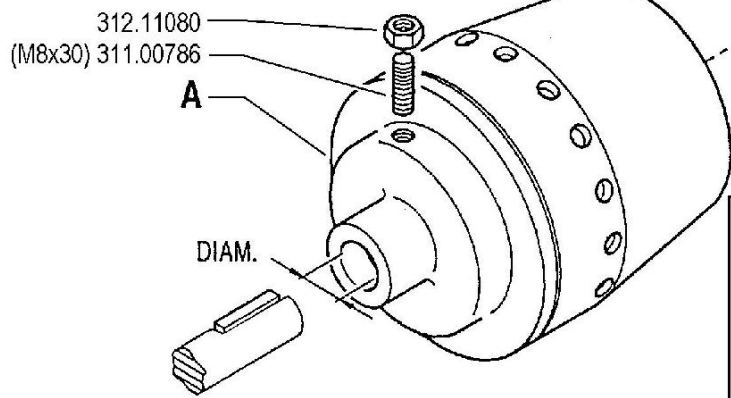
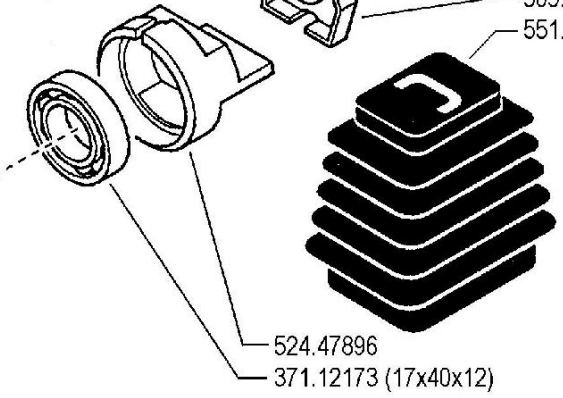
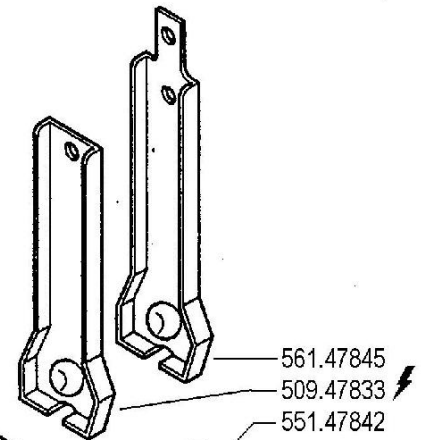
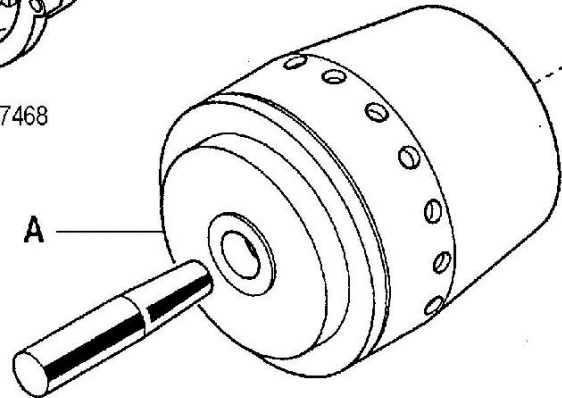

MOTORE ENGINE MOTEUR MOTOR	A	FRIZIONE EMBRAYAGE KUPPLUNG CLUTCH
Acme A 220		592.47884
Acme ALN 330W - ACT 280 ★		592.47884
Acme AT 330W - ACT 340 ★		592.47971
Honda G150 - Gx160 - Gx200 ★		592.56252
Intermotor IM 359		592.47884
Lombardini 15 LD 315 / 350		592.47884
Yanmar L100 AE ★		592.47971

**NON SMONTARE MAI LA FRIZIONE
NEVER DISASSEMBLE THE CLUTCH
NE DEMONTER JAMAIS L'EMBRAYAGE
NIEMALS DIE KUPPLUNG AUSBAUEN
NO DESMONTAR JAMAS EL EMBRAGUE**

V = verde - green - vert - grün

FERRARI	500 serie 95	FRIZIONE A CONO AUTOVENTILANTE		DALLA MACCHINA DE LA MAQUINA DE LA MACHINE FROM THE MACHINE AB DER MASCHINE	AGGIORNAMENTO	02	Mod. 02
		CLUTCH	EMBRAYAGE		REVISION		
		EMBRAGUE	KUPPLUNG		MISE A JOUR		
					APLAZAMIENTO		
					ANPASSUNG		
			★N.	1/2000			

Pos.	Code	Q.ty	Description	Notes
31100003	31100003	0	SCREW TE 5/16X7/8	
31100786	31100786	0	SCREW STEI M8X30 UNI5923 8G	
31211080	31211080	0	NUT M8	
31312083	31312083	0	STUD BOLT M8X46X16X16	
31312088	31312088	0	STUD BOLT M8X40X14X14	
31423084	31423084	0	SPRING WASHER 8,4	
37112173	37112173	0	BEARING	
37112231	37112231	0	BEARING	
50947833	50947833	0	CLUTCH LEVER	
52447896	52447896	0	PRESSURE PLATE	
53247468	53247468	0	FLANGE	
55147842	55147842	0	BELLOWS	
56147845	56147845	0	CLUTCH LEVER	
56356251	56356251	0	SHIM D=19,6	
59247884	59247884	0	CLUTCH ASSY	
59247971	59247971	0	CLUTCH	
59256252	59256252	0	CLUTCH ASSY	

HONDA G150 - Gx 120/160/200 311.00003
 HONDA Gx 340 ★ 311.00015

HONDA Gx 340 ★ 314.23105

371.12231 HONDA G150 - Gx 120/160/200
 371.12233 (30x55x13) - HONDA Gx 340 ★

563.47484 - HONDA Gx 340 ★
 563.56251 HONDA G150 - Gx 120/160/200

312.11080
 314.23084

313.12088 (M8x40)
 313.12083 (M8x46) (15LD315/350 - ACT 280/340 - L100AE)

HONDA G150 - Gx 120/160/200 (2) ★ 532.47488
 HONDA Gx 340 ★ 531.56150

MOTORE ENGINE MOTEUR MOTOR	FRIZIONE EMBRAGUE EMBAYAGE KUPPLUNG CLUTCH
Acme A220	592.47884
Acme ACT 280 - A349 ★ - A360 ★	592.47884
Acme ACT 340	592.47971
Honda Gx 340 ★	592.56257
Honda G150 - Gx 120 / 160 / 200	592.56265 ★ (1)
Intermotor IM 359	592.47884
Lombardini 15LD315 / 350	592.47884
Yanmar L100AE	592.47971

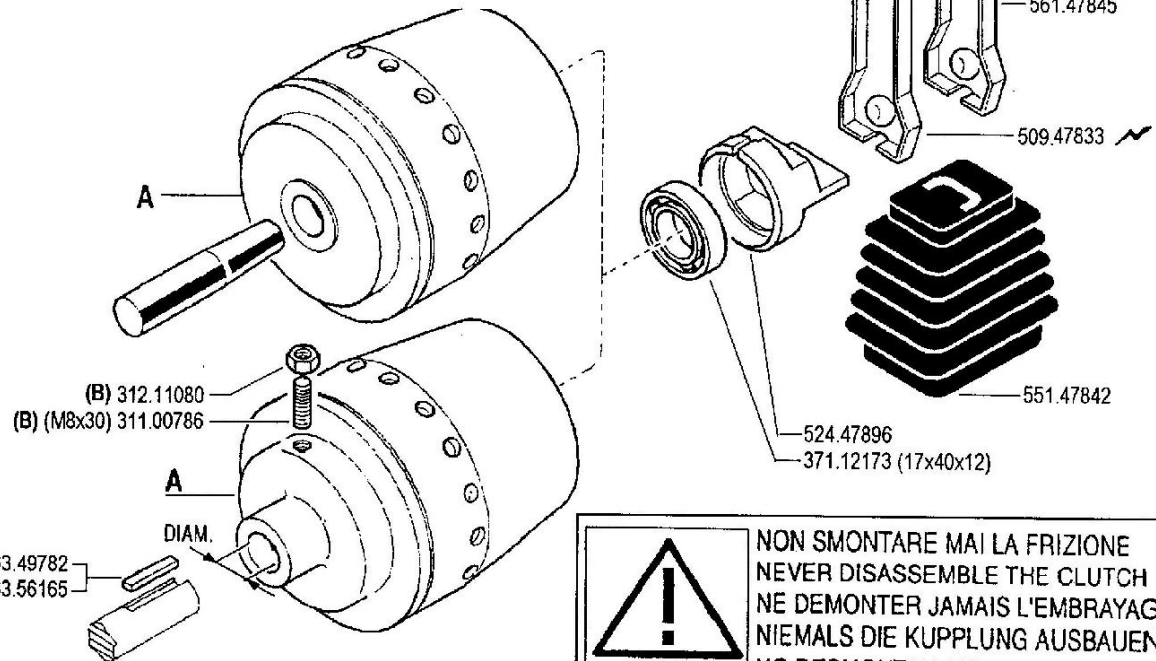

(HONDA Gx 340 ★) 563.49782
 (HONDA G150 - Gx120/160/200) ★ 563.56165

(2) sostituisce **V532.47468**
 (1) sostituisce **592.56252**

**! NON SMONTARE MAI LA FRIZIONE
 NEVER DISASSEMBLE THE CLUTCH
 NE DEMONTER JAMAIS L'EMBRAYAGE
 NIEMALS DIE KUPPLUNG AUSBAUEN
 NO DESMONTAR JAMAS EL EMBRAGUE**

(B) serrare a 2 kgm

FERRARI

500 serie 95

FRIZIONE A CONO AUTOVENTILANTE

CLUTCH
 EMBRAGUE

EMBRAYAGE
 KUPPLUNG

DALLA MACCHINA
 DE LA MAQUINA
 DE LA MACHINE
 FROM THE MACHINE
 AB DER MASCHINE

(1) 4194 (515)
 (1) 166207 (520)

02

Rev.
3

★N.

12/2002

ZENNE

Pos.	Code	Q.ty	Description	Notes
31100003	31100003	0	SCREW TE 5/16X7/8	
31100015	31100015	0	SCREW TE 3/8X1	
31100786	31100786	0	SCREW STEI M8X30 UNI5923 8G	
31211080	31211080	0	NUT M8	
31312083	31312083	0	STUD BOLT M8X46X16X16	
31312088	31312088	0	STUD BOLT M8X40X14X14	
31423084	31423084	0	SPRING WASHER 8,4	
31423105	31423105	0	SPRING WASHER 10,5	
37112173	37112173	0	BEARING	
37112231	37112231	0	BEARING	
37112233	37112233	0	BEARING	
50947833	50947833	0	CLUTCH LEVER	
52447896	52447896	0	PRESSURE PLATE	
53156150	53156150	0	ENGINE FLANGE	
53247488	53247488	0	ENGINE FLANGE	
55147842	55147842	0	BELLOWS	
56147845	56147845	0	CLUTCH LEVER	
56347484	56347484	0	SHIM	
56349782	56349782	0	DOWEL	
56356165	56356165	0	DOWEL	
56356251	56356251	0	SHIM D=19,6	
59247884	59247884	0	CLUTCH ASSY	
59247971	59247971	0	CLUTCH	
59256257	59256257	0	CLUTCH ASSY	
59256265	59256265	0	CLUTCH ASSY	

SERIAL

002_03 - SELF-VENTILATING CONE CLUTCH

CODE REV

002_3_12779

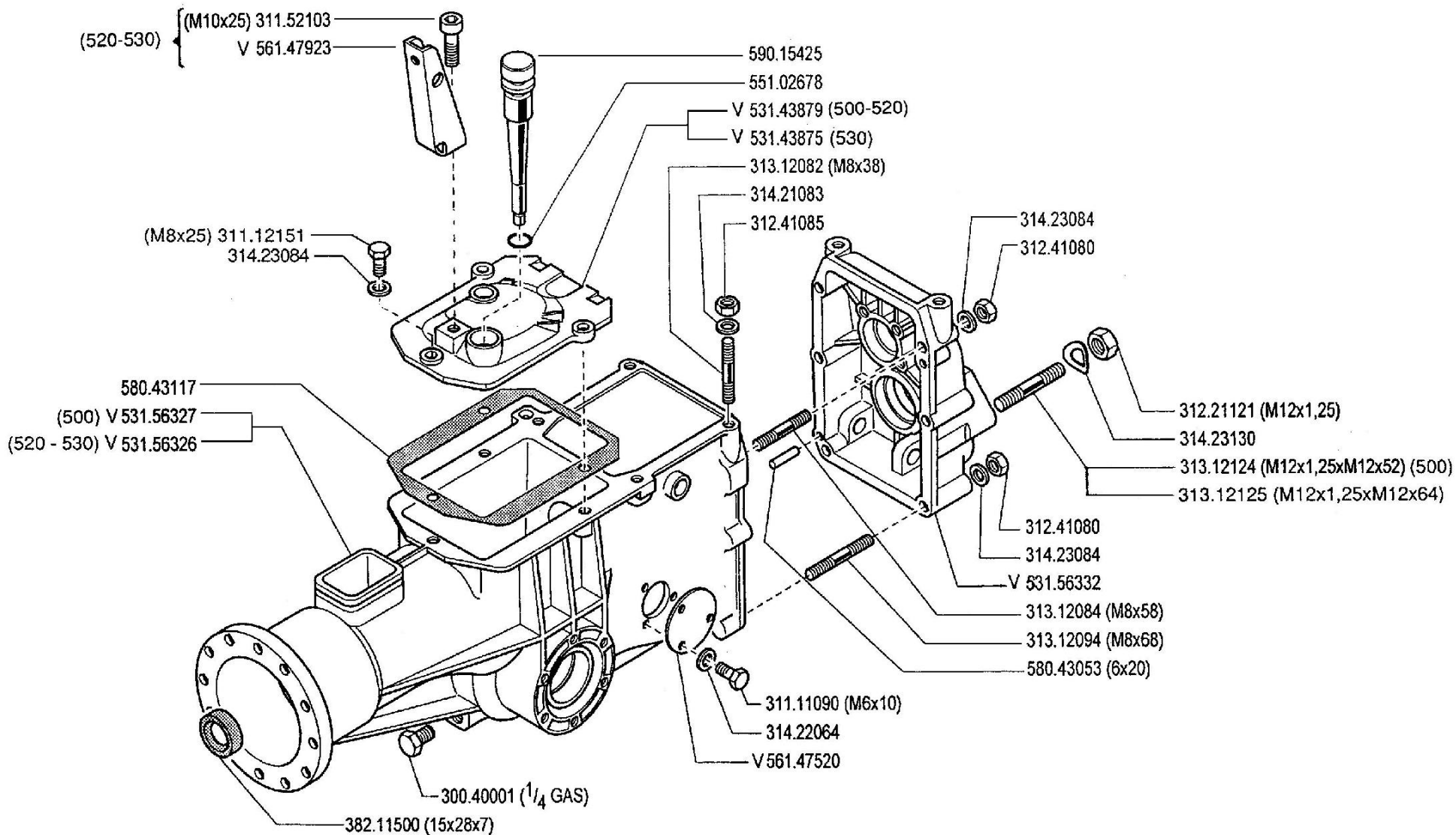

V = verde - green - vert - grün

	500 serie 95	SCATOLA CAMBIO		DALLA MACCHINA DE LA MAQUINA DE LA MACHINE FROM THE MACHINE AB DER MASCHINE	03 00	N.	6/1995	ZENNE
		GEARBOX CAJA DE CAMBIO	BOITE DE VITESSES WECHSELGETRIEBE					

Pos.	Code	Q.ty	Description	Notes
30040001	30040001	0	PLUG	
31111090	31111090	0	SCREW TE M5X10 UNI 5739 8G	
31112151	31112151	0	SCREW TE M8X25 UNI 5739 8G	
31152103	31152103	0	SCREW TCEI M10X25 UNI 5931	
31221121	31221121	0	NUT M12X1,25	
31241080	31241080	0	HEXAGON SELFLOCK NUT M8	
31241085	31241085	0	SELFLOCK NUT M8 6S	
31312082	31312082	0	STUD BOLT M8X38X14X20	
31312084	31312084	0	STUD BOLT M8X58X16X16	
31312094	31312094	0	STUD BOLT M8X68X14X36	
31312124	31312124	0	STUD BOLT	
31312125	31312125	0	STUD BOLT	
31421083	31421083	0	WASHER	
31422064	31422064	0	SPRING WASHER 6,4	
31423084	31423084	0	SPRING WASHER 8,4	
31423130	31423130	0	SPRING WASHER 13	
38211500	38211500	0	OIL SEAL 15X28X7	
53143875	53143875	0	GEARBOX HOUSING COVER	
53143879	53143879	0	GEARBOX HOUSING COVER	
53156326	53156326	0	BODY	
53156327	53156327	0	BODY	
53156332	53156332	0	REAR COVER	
55102678	55102678	0	RUBBER RING	
56147520	56147520	0	COVER	
56147923	56147923	0	BRACKET	
58043053	58043053	0	CYLINDRICAL PLUG	
58043117	58043117	0	COVER GASKET	
59015425	59015425	0	PLUG	

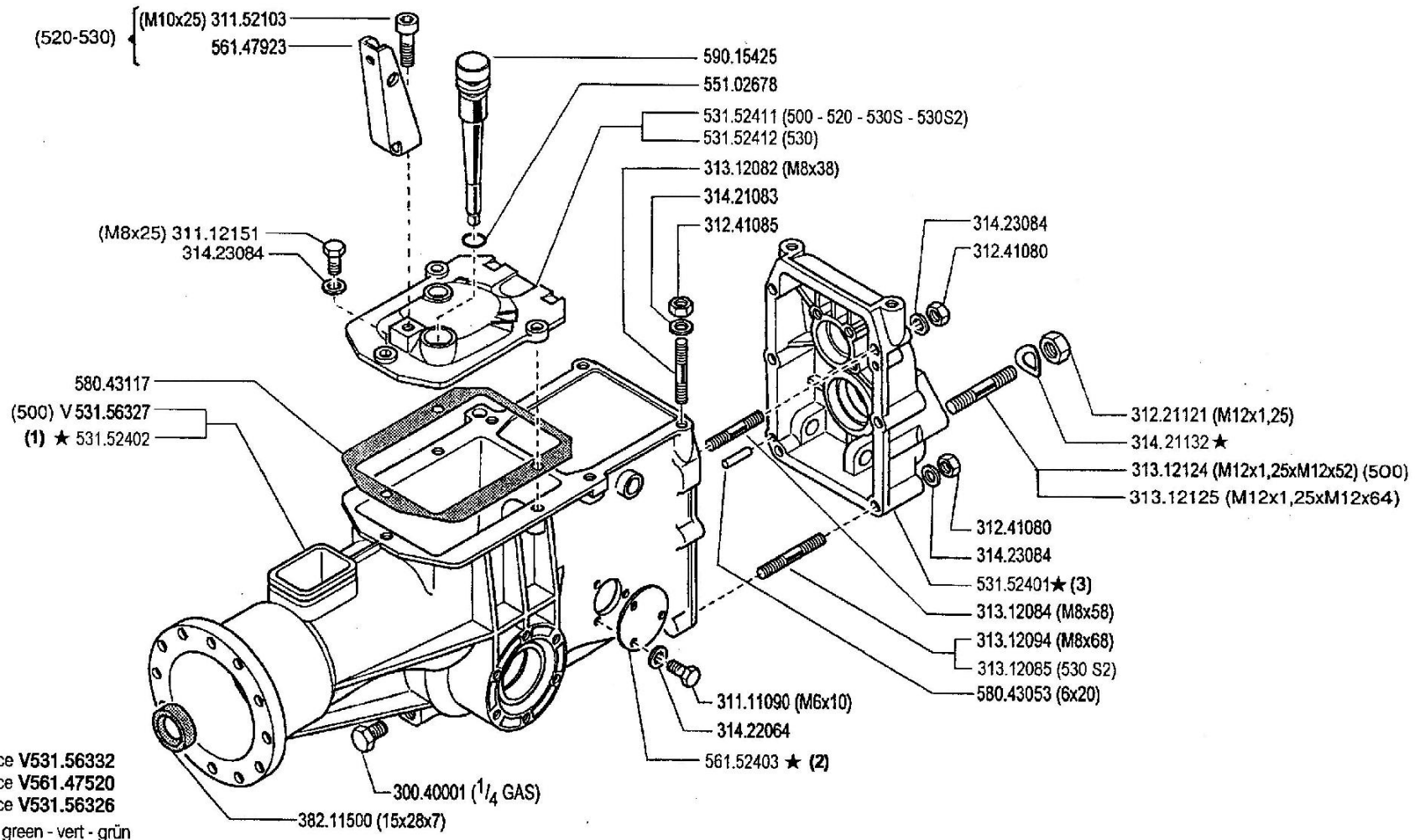

(3) sostituisce V531.56332
 (2) sostituisce V561.47520
 (1) sostituisce V531.56326
 V = verde - green - vert - grün

FERRARI

500 serie 95

SCATOLA CAMBIO (500 - 520 - 530 - 530S - 530S2)

GEARBOX
CAJA DE CAMBIO

BOITE DE VITESSES
WECHSELGETRIEBE

DALLA MACCHINA
DE LA MAQUINA
FROM THE MACHINE
AB DER MASCHINE

AGGIORNAMENTO
REVISION
MISE A JOUR
APLAZAMIENTO
ANPASSUNG

03

Rev.
1

12/2002

★ N.

ZENNE

Pos.	Code	Q.ty	Description	Notes
30040001	30040001	0	PLUG	
31111090	31111090	0	SCREW TE M5X10 UNI 5739 8G	
31112151	31112151	0	SCREW TE M8X25 UNI 5739 8G	
31152103	31152103	0	SCREW TCEI M10X25 UNI 5931	
31221121	31221121	0	NUT M12X1,25	
31241080	31241080	0	HEXAGON SELFLOCK NUT M8	
31241085	31241085	0	SELFLOCK NUT M8 6S	
31312082	31312082	0	STUD BOLT M8X38X14X20	
31312084	31312084	0	STUD BOLT M8X58X16X16	
31312085	31312085	0	STUD BOLT M8X80X28X16	
31312094	31312094	0	STUD BOLT M8X68X14X36	
31312124	31312124	0	STUD BOLT	
31312125	31312125	0	STUD BOLT	
31421083	31421083	0	WASHER	
31421132	31421132	0	WASHER 13X24X2,8	
31422064	31422064	0	SPRING WASHER 6,4	
31423084	31423084	0	SPRING WASHER 8,4	
38211500	38211500	0	OIL SEAL 15X28X7	
53152401	53152401	0	REAR COVER	
53152402	53152402	0	BODY	
53152411	53152411	0	GEARBOX HOUSING COVER	
53152412	53152412	0	COVER	
53156327	53156327	0	BODY	
55102678	55102678	0	RUBBER RING	
56147923	56147923	0	BRACKET	
56152403	56152403	0	COVER	
58043053	58043053	0	CYLINDRICAL PLUG	
58043117	58043117	0	COVER GASKET	
59015425	59015425	0	PLUG	

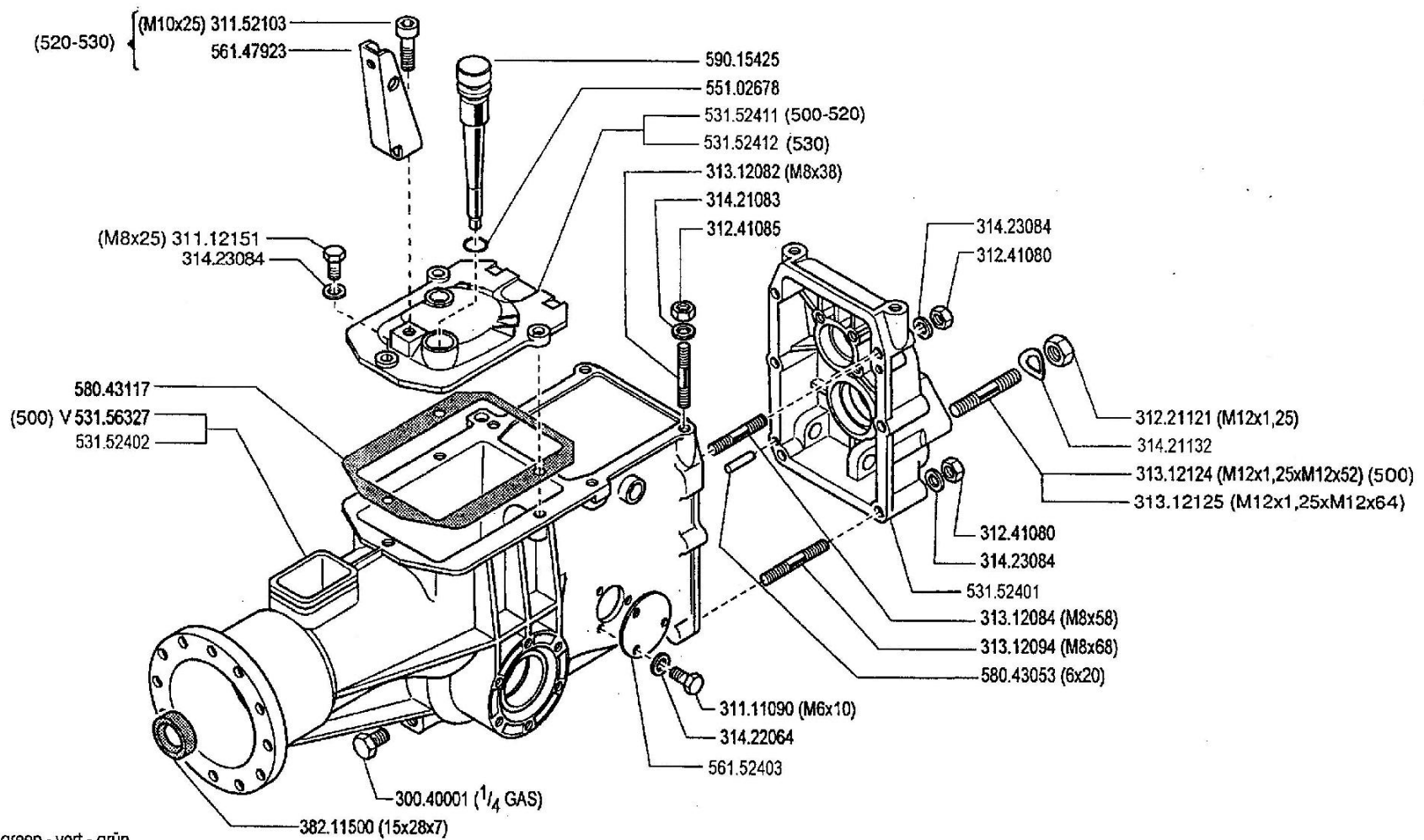

FERRARI

500 serie **95**

SCATOLA CAMBIO (500 - 520 - 530) ★

GEARBOX
CAJA DE CAMBIO

BOITE DE VITESSES
WECHSELGETRIEBE

DALLA MACCHINA
DE LA MAQUINA
DE LA MACHINE
FROM THE MACHINE
AB DER MASCHINE

AGGIORNAMENTO

REVISION

MISE A JOUR

APLAZAMIENTO

ANPASSUNG

03

Rev.
2

1/2004

★ N

ZENITE

Pos.	Code	Q.ty	Description	Notes
30040001	30040001	0	PLUG	
31111090	31111090	0	SCREW TE M5X10 UNI 5739 8G	
31112151	31112151	0	SCREW TE M8X25 UNI 5739 8G	
31152103	31152103	0	SCREW TCEI M10X25 UNI 5931	
31221121	31221121	0	NUT M12X1,25	
31241080	31241080	0	HEXAGON SELFLOCK NUT M8	
31241085	31241085	0	SELFLOCK NUT M8 6S	
31312082	31312082	0	STUD BOLT M8X38X14X20	
31312084	31312084	0	STUD BOLT M8X58X16X16	
31312094	31312094	0	STUD BOLT M8X68X14X36	
31312124	31312124	0	STUD BOLT	
31312125	31312125	0	STUD BOLT	
31421083	31421083	0	WASHER	
31421132	31421132	0	WASHER 13X24X2,8	
31422064	31422064	0	SPRING WASHER 6,4	
31423084	31423084	0	SPRING WASHER 8,4	
38211500	38211500	0	OIL SEAL 15X28X7	
53152401	53152401	0	REAR COVER	
53152402	53152402	0	BODY	
53152411	53152411	0	GEARBOX HOUSING COVER	
53152412	53152412	0	COVER	
53156327	53156327	0	BODY	
55102678	55102678	0	RUBBER RING	
56147923	56147923	0	BRACKET	
56152403	56152403	0	COVER	
58043053	58043053	0	CYLINDRICAL PLUG	
58043117	58043117	0	COVER GASKET	
59015425	59015425	0	PLUG	

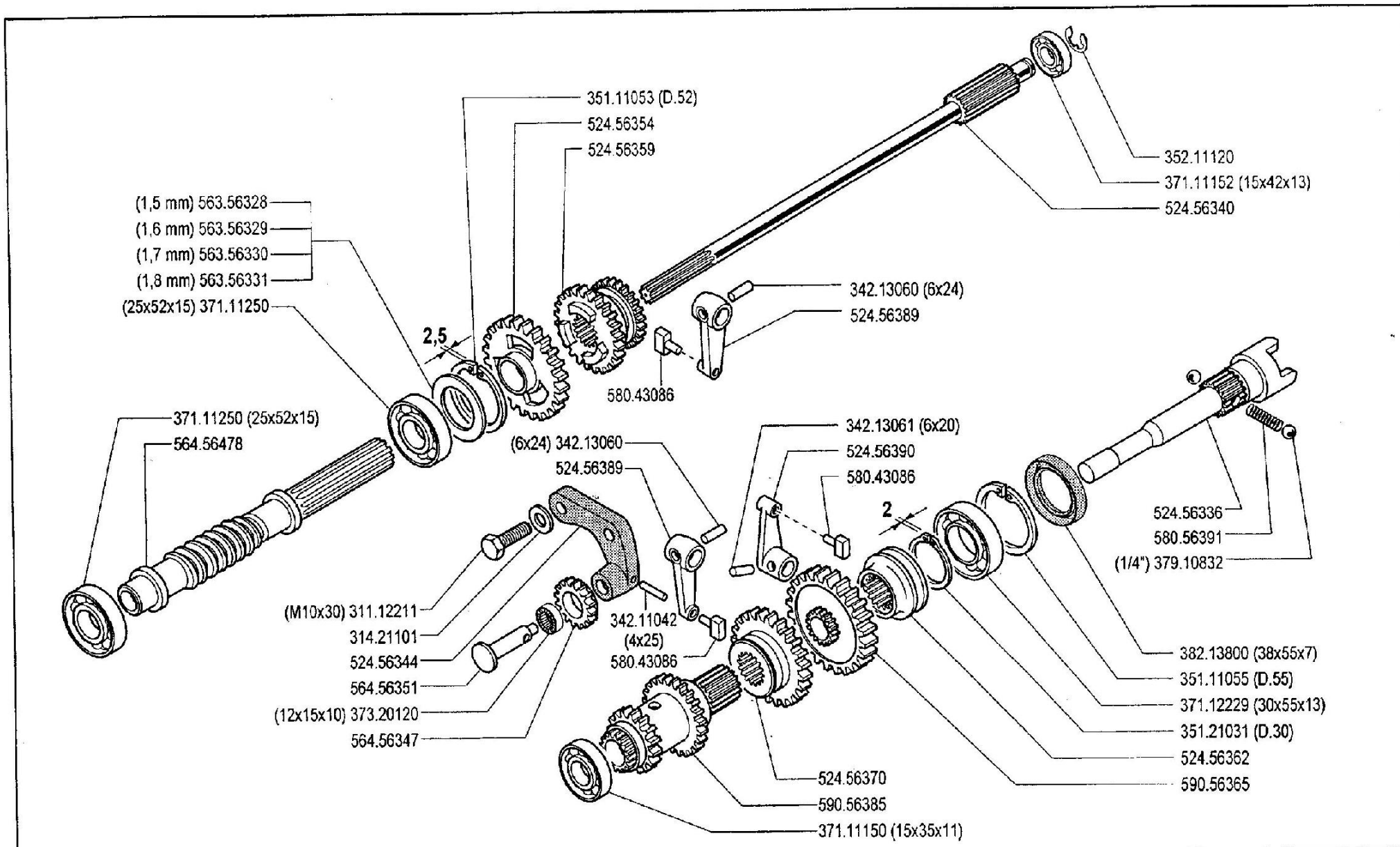

FERRARI

500 serie **95**

INGRANAGGI CAMBIO

ENGRANAJES
ENGRANAGES

GEARS
ZÄHNRÄDER

DALLA MACCHINA
DE LA MAQUINA
DE LA MACHINE
FROM THE MACHINE
AB DER MASCHINE

N.

04.00

01.06.1995

Pos.	Code	Q.ty	Description	Notes
31112211	31112211	0	SCREW TE M10X30 UNI 5739	
31421101	31421101	0	WASHER	
34211042	34211042	0	ROLL PIN	
34213060	34213060	0	ROLL PIN	
34213061	34213061	0	ROLL PIN	
35111053	35111053	0	SEEGER RING I 52 UNI 7438	
35111055	35111055	0	SEEGER RING	
35121031	35121031	0	SEEGER RING	
35211120	35211120	0	SEEGER RING	
37111150	37111150	0	BEARING	
37111152	37111152	0	BEARING	
37111250	37111250	0	BEARING	
37112229	37112229	0	BEARING	
37320120	37320120	0	ROLLER CAGE 12X15/10	
37910832	37910832	0	BALL 1/4	
38213800	38213800	0	OIL SEAL 38X55X7	
52456336	52456336	0	PTO SHAFT	
52456340	52456340	0	SHAFT	
52456344	52456344	0	GEAR SUPPORT	
52456354	52456354	0	GEAR	
52456359	52456359	0	SLIDER	
52456362	52456362	0	COUPLING	
52456370	52456370	0	SLIDER	
52456389	52456389	0	LEVER	
52456390	52456390	0	LEVER	
56356328	56356328	0	ADJUSTING RING SP=1,5	
56356329	56356329	0	ADJUSTING RING SP=1,6	
56356330	56356330	0	ADJUSTING RING SP=1,7	
56356331	56356331	0	ADJUSTING RING SP=1,8	
56456347	56456347	0	GEAR	
56456351	56456351	0	GEAR PIN	
56456478	56456478	0	SCREW	
58043086	58043086	0	SHOE	
58056391	58056391	0	SPRING	

SERIAL

004_00 - GEARS

CODE REV

004_0_12893

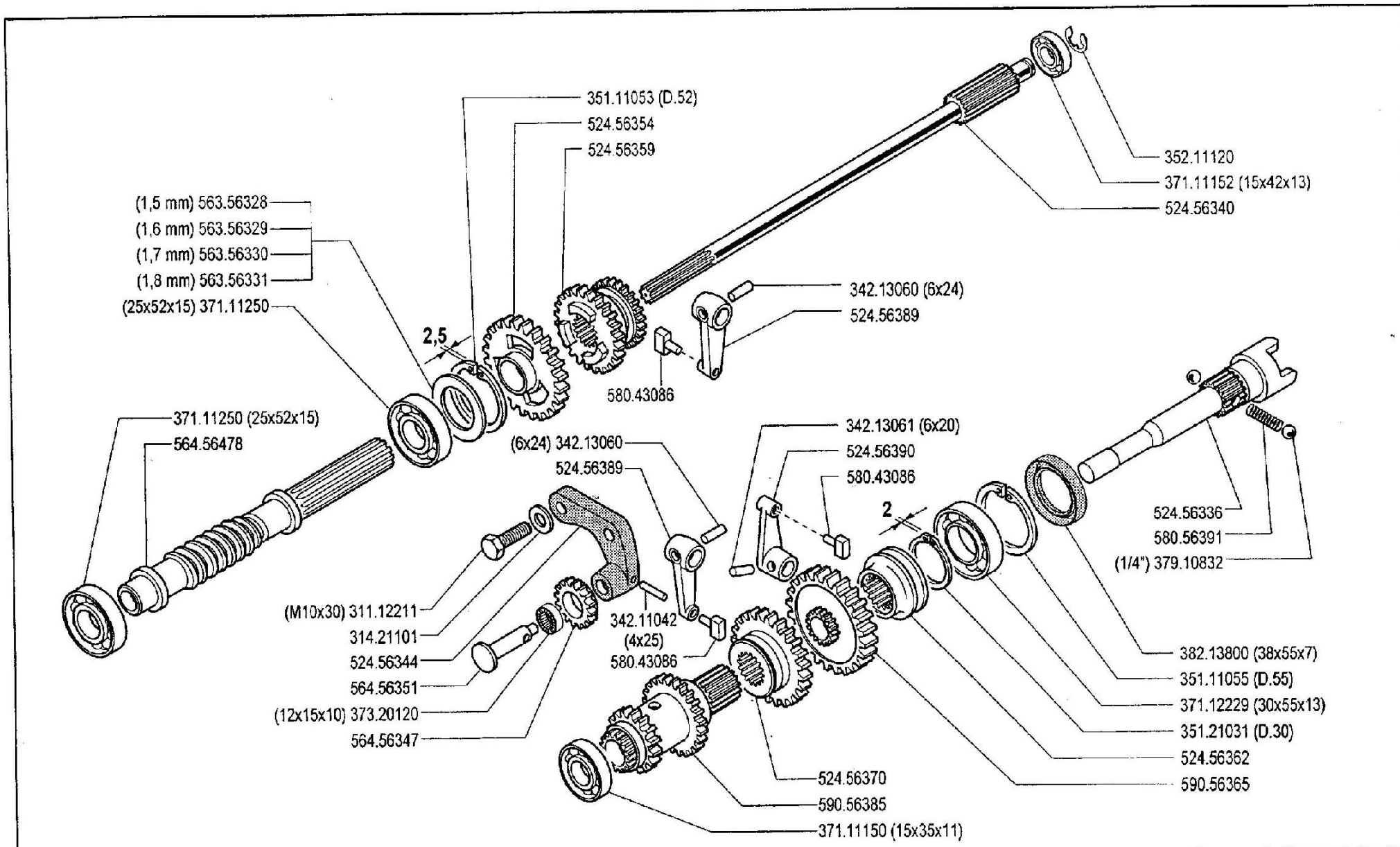

FERRARI

500 serie **95**

INGRANAGGI CAMBIO

ENGRANAJES
ENGRANAGES

GEARS
ZÄHNRÄDER

DALLA MACCHINA
DE LA MAQUINA
DE LA MACHINE
FROM THE MACHINE
AB DER MASCHINE

N.

04.00

01.06.1995

Pos.	Code	Q.ty	Description	Notes
59056365	59056365	0	PTO GEAR	
59056385	59056385	0	TRIPLE GEAR	

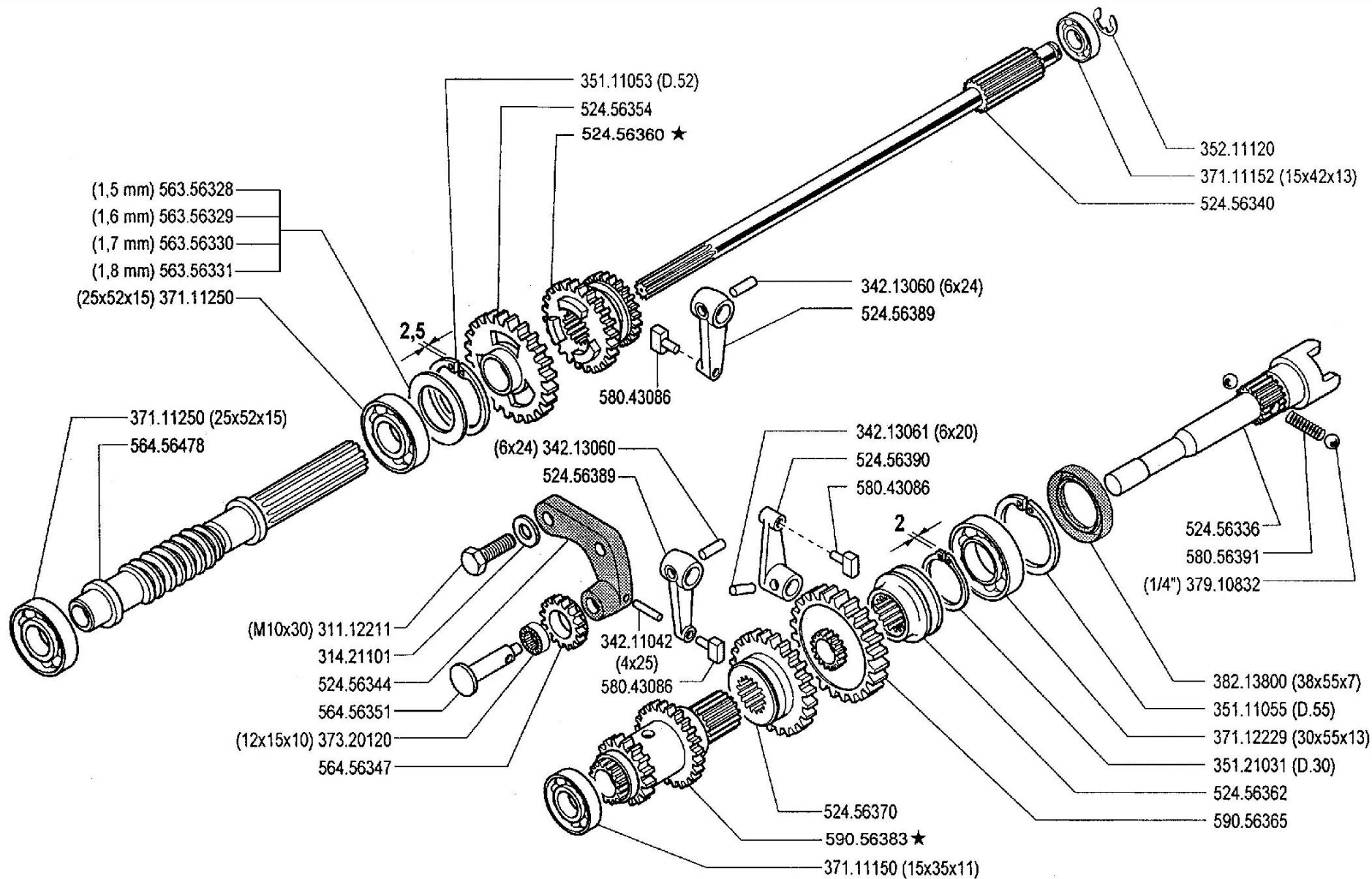

- (1,5 mm) 563.56328
- (1,6 mm) 563.56329
- (1,7 mm) 563.56330
- (1,8 mm) 563.56331
- (25x52x15) 371.11250
- 351.11053 (D.52)
- 524.56354
- 524.56360 ★
- 352.11120
- 371.11152 (15x42x13)
- 524.56340
- 342.13060 (6x24)
- 524.56389
- 580.43086
- 371.11250 (25x52x15)
- 564.56478
- 2,5
- (6x24) 342.13060
- 524.56389
- 342.13061 (6x20)
- 524.56390
- 580.43086
- 2
- 524.56336
- 580.56391
- (1/4") 379.10832
- (M10x30) 311.12211
- 314.21101
- 524.56344
- 564.56351
- (12x15x10) 373.20120
- 564.56347
- 342.11042 (4x25)
- 580.43086
- 382.13800 (38x55x7)
- 351.11055 (D.55)
- 371.12229 (30x55x13)
- 351.21031 (D.30)
- 524.56362
- 590.56365
- 524.56370
- 590.56383 ★
- 371.11150 (15x35x11)

FERRARI

500 serie **95**

INGRANAGGI CAMBIO

GEARS
ENGRANAJES

ENGRANAGES
ZÄHRÄDER

DALLA MACCHINA
DE LA MAQUINA
DE LA MACHINE
FROM THE MACHINE
AB DER MASCHINE

★N.

	21882 (530)
	156431 (520)
	80754 (500)

04 **01**
10/1996

ZENIT

Pos.	Code	Q.ty	Description	Notes
31112211	31112211	0	SCREW TE M10X30 UNI 5739	
31421101	31421101	0	WASHER	
34211042	34211042	0	ROLL PIN	
34213060	34213060	0	ROLL PIN	
34213061	34213061	0	ROLL PIN	
35111053	35111053	0	SEEGER RING I 52 UNI 7438	
35111055	35111055	0	SEEGER RING	
35121031	35121031	0	SEEGER RING	
35211120	35211120	0	SEEGER RING	
37111150	37111150	0	BEARING	
37111152	37111152	0	BEARING	
37111250	37111250	0	BEARING	
37112229	37112229	0	BEARING	
37320120	37320120	0	ROLLER CAGE 12X15/10	
37910832	37910832	0	BALL 1/4	
38213800	38213800	0	OIL SEAL 38X55X7	
52456336	52456336	0	PTO SHAFT	
52456340	52456340	0	SHAFT	
52456344	52456344	0	GEAR SUPPORT	
52456354	52456354	0	GEAR	
52456360	52456360	0	SLIDER	
52456362	52456362	0	COUPLING	
52456370	52456370	0	SLIDER	
52456389	52456389	0	LEVER	
52456390	52456390	0	LEVER	
56356328	56356328	0	ADJUSTING RING SP=1,5	
56356329	56356329	0	ADJUSTING RING SP=1,6	
56356330	56356330	0	ADJUSTING RING SP=1,7	
56356331	56356331	0	ADJUSTING RING SP=1,8	
56456347	56456347	0	GEAR	
56456351	56456351	0	GEAR PIN	
56456478	56456478	0	SCREW	
58043086	58043086	0	SHOE	
58056391	58056391	0	SPRING	

SERIAL

004_01 - GEARS

Version: MF 530, MF 500, MF 520

CODE REV

004_1_12930

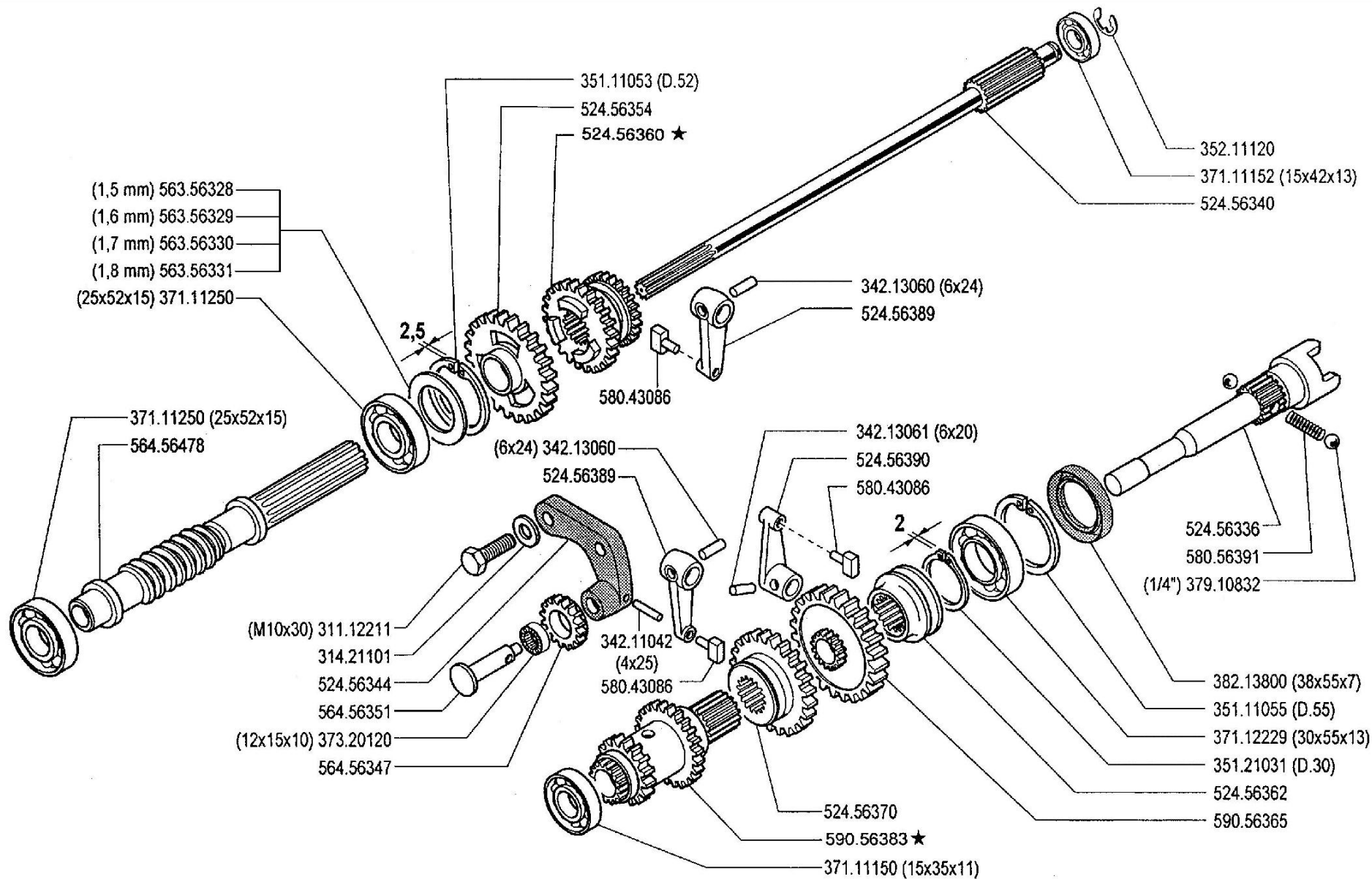

- (1,5 mm) 563.56328
- (1,6 mm) 563.56329
- (1,7 mm) 563.56330
- (1,8 mm) 563.56331
- (25x52x15) 371.11250
- 351.11053 (D.52)
- 524.56354
- 524.56360 ★
- 352.11120
- 371.11152 (15x42x13)
- 524.56340
- 342.13060 (6x24)
- 524.56389
- 580.43086
- 371.11250 (25x52x15)
- 564.56478
- 2,5
- 342.13060 (6x24)
- 524.56389
- 580.43086
- 342.13061 (6x20)
- 524.56390
- 580.43086
- 2
- 524.56336
- 580.56391
- (1/4") 379.10832
- (M10x30) 311.12211
- 314.21101
- 524.56344
- 564.56351
- (12x15x10) 373.20120
- 564.56347
- 342.11042 (4x25)
- 580.43086
- 382.13800 (38x55x7)
- 351.11055 (D.55)
- 371.12229 (30x55x13)
- 351.21031 (D.30)
- 524.56362
- 590.56365
- 524.56370
- 590.56383 ★
- 371.11150 (15x35x11)

FERRARI

500 serie **95**

INGRANAGGI CAMBIO

GEARS
ENGRANAJES

ENGRANAGES
ZÄHNRÄDER

DALLA MACCHINA
DE LA MAQUINA
DE LA MACHINE
FROM THE MACHINE
AB DER MASCHINE

★N.

	21882 (530)
	156431 (520)
	80754 (500)

04 **01**
10/1996

ZENIT

Pos.	Code	Q.ty	Description	Notes
59056365	59056365	0	PTO GEAR	
59056383	59056383	0	TRIPLE GEAR	

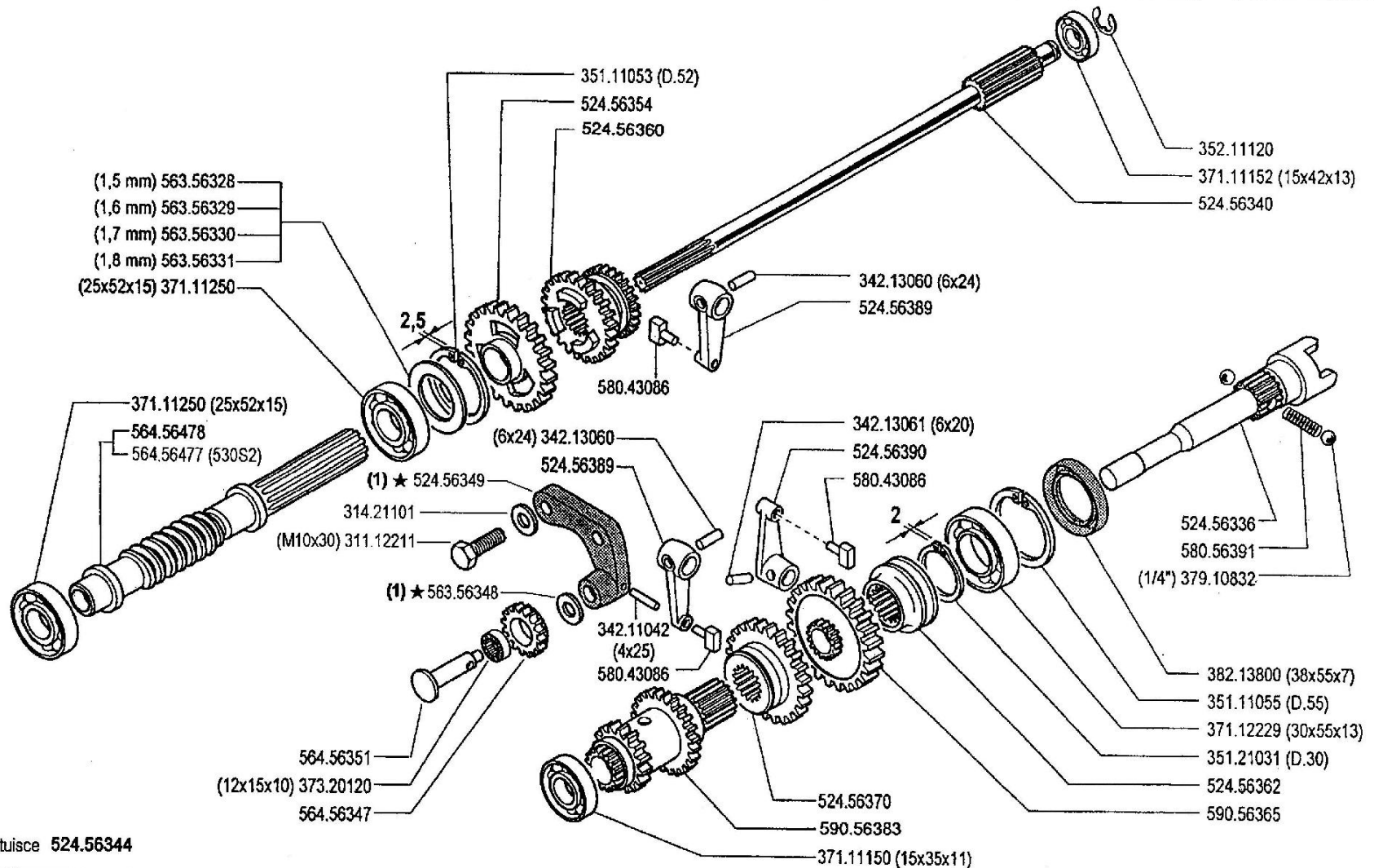

(1) sostituisce 524.56344

FERRARI

500 serie 95

INGRANAGGI CAMBIO (500 - 520 - 530 - 530S - 530S2) ★

GEARS
ENGRANAJES

ENGRANAGES
ZAHNRÄDER

DALLA MACCHINA
DE LA MAQUINA
DE LA MACHINE
FROM THE MACHINE
AB DER MASCHINE

★N.

AGGIORNAMENTO
REVISION
MISE A JOUR
APLAZAMIENTO
ANPASSUNG

04

Rev.
2

9/2000

ZENNE

Pos.	Code	Q.ty	Description	Notes
31112211	31112211	0	SCREW TE M10X30 UNI 5739	
31421101	31421101	0	WASHER	
34211042	34211042	0	ROLL PIN	
34213060	34213060	0	ROLL PIN	
34213061	34213061	0	ROLL PIN	
35111053	35111053	0	SEEGER RING I 52 UNI 7438	
35111055	35111055	0	SEEGER RING	
35121031	35121031	0	SEEGER RING	
35211120	35211120	0	SEEGER RING	
37111150	37111150	0	BEARING	
37111152	37111152	0	BEARING	
37111250	37111250	0	BEARING	
37112229	37112229	0	BEARING	
37320120	37320120	0	ROLLER CAGE 12X15/10	
37910832	37910832	0	BALL 1/4	
38213800	38213800	0	OIL SEAL 38X55X7	
52456336	52456336	0	PTO SHAFT	
52456340	52456340	0	SHAFT	
52456349	52456349	0	GEAR SUPPORT	
52456354	52456354	0	GEAR	
52456360	52456360	0	SLIDER	
52456362	52456362	0	COUPLING	
52456370	52456370	0	SLIDER	
52456389	52456389	0	LEVER	
52456390	52456390	0	LEVER	
56356328	56356328	0	ADJUSTING RING SP=1,5	
56356329	56356329	0	ADJUSTING RING SP=1,6	
56356330	56356330	0	ADJUSTING RING SP=1,7	
56356331	56356331	0	ADJUSTING RING SP=1,8	
56356348	56356348	0	ADJUSTING RING	
56456347	56456347	0	GEAR	
56456351	56456351	0	GEAR PIN	
56456477	56456477	0	SCREW	
56456478	56456478	0	SCREW	

SERIAL

004_02 - GEARS (500-520/30-530S/S2)

CODE REV

004_2_12967

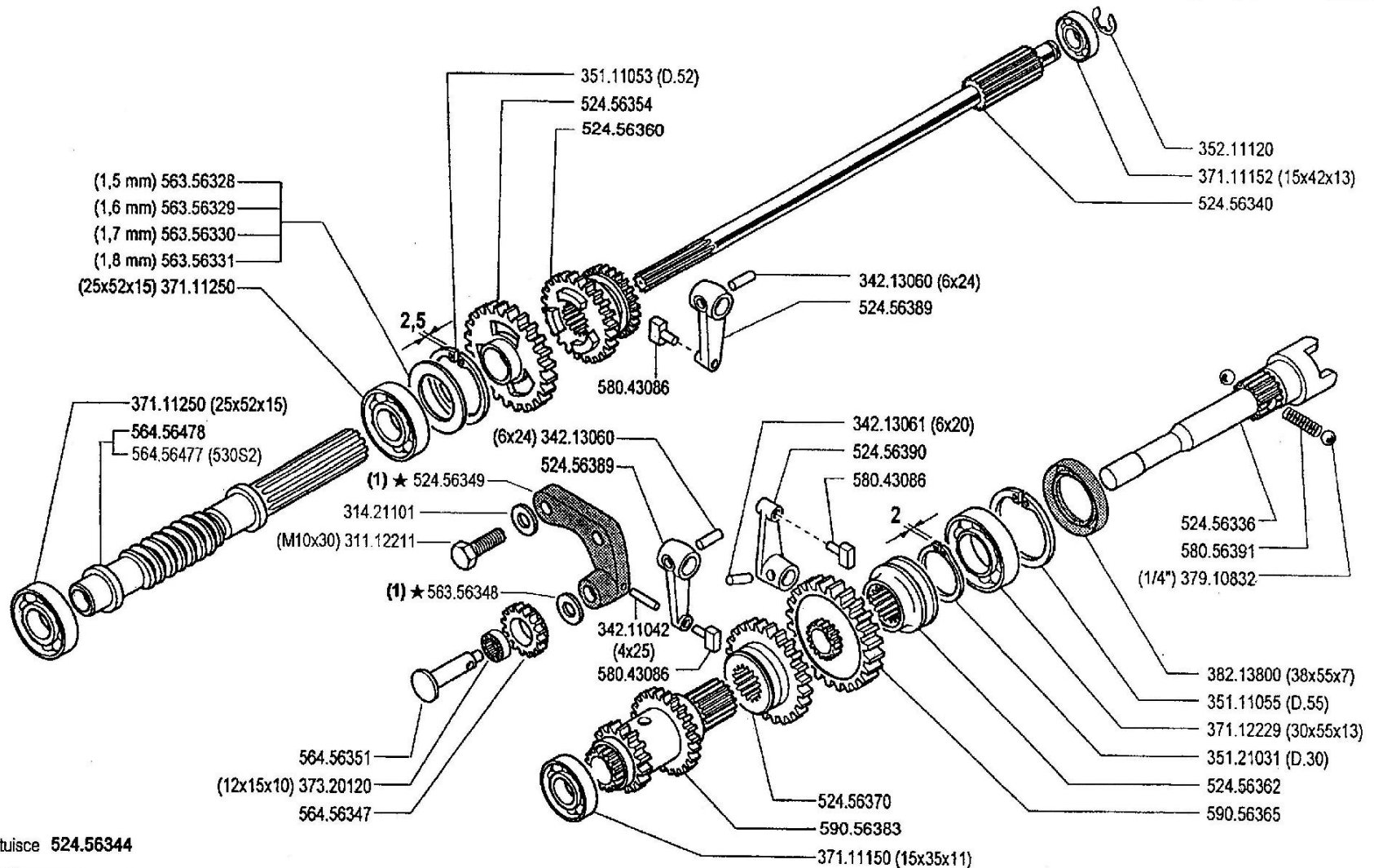

(1) sostituisce 524.56344

FERRARI

500 serie 95

INGRANAGGI CAMBIO (500 - 520 - 530 - 530S - 530S2) ★

GEARS
ENGRANAJES

ENGRANAGES
ZAHNRÄDER

DALLA MACCHINA
DE LA MAQUINA
DE LA MACHINE
FROM THE MACHINE
AB DER MASCHINE

★N.

AGGIORNAMENTO
REVISION
MISE A JOUR
APLAZAMIENTO
ANPASSUNG

04

Rev.
2

9/2000

ZENNE

Pos.	Code	Q.ty	Description	Notes
58043086	58043086	0	SHOE	
58056391	58056391	0	SPRING	
59056365	59056365	0	PTO GEAR	
59056383	59056383	0	TRIPLE GEAR	

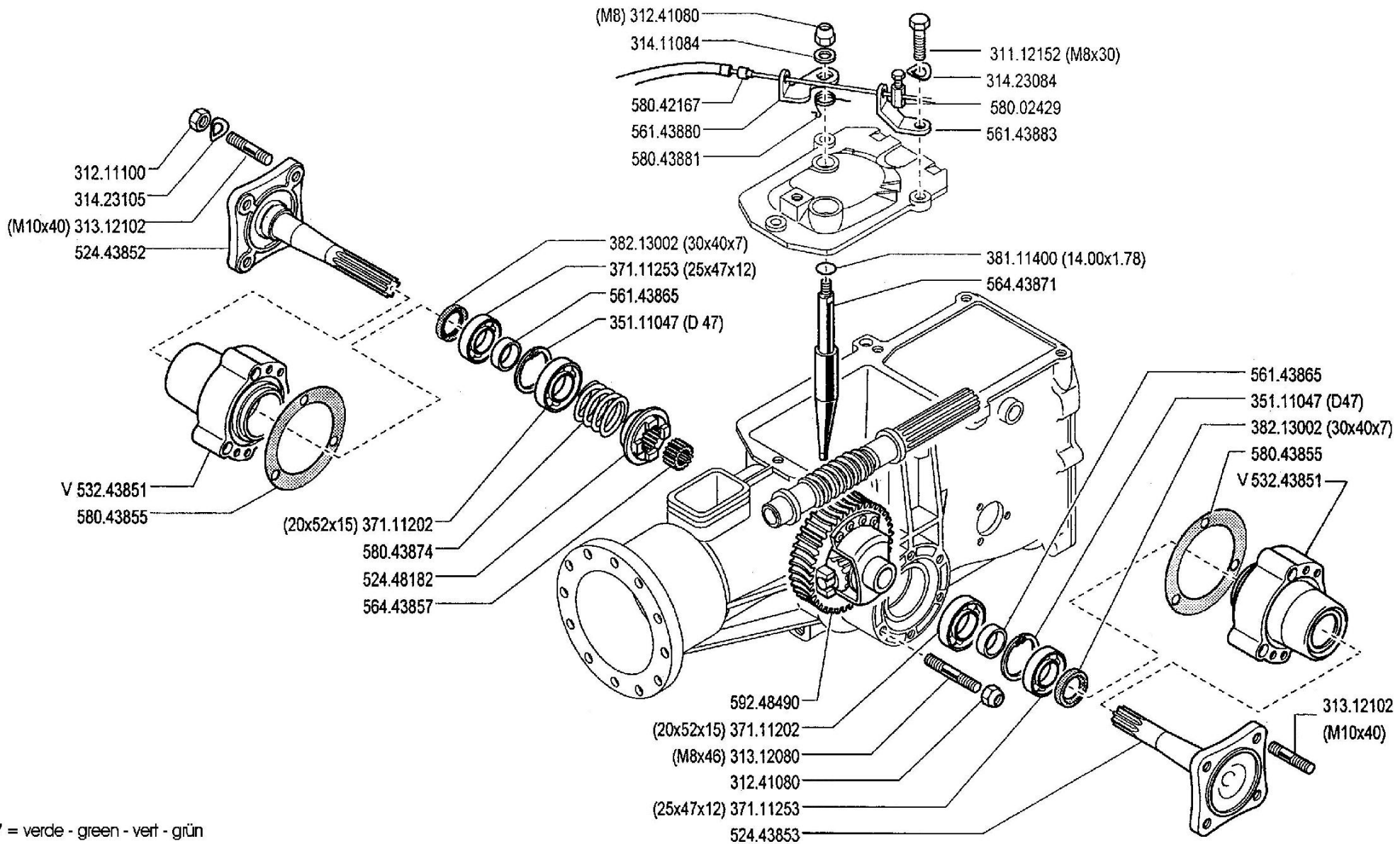

V = verde - green - vert - grün

FERRARI

500 serie **95**

DIFFERENTIAL
DIFFERENCIAL

DIFFERENZIALE (530)

DIFFERENTIEL
DIFFERENTIAL

DALLA MACCHINA
DE LA MAQUINA
DE LA MACHINE
FROM THE MACHINE
AB DER MASCHINE

N.

06

00

6/1995

ZENNE

Pos.	Code	Q.ty	Description	Notes
31112152	31112152	0	SCREW TE M8X30 UNI 5739 8G	
31211100	31211100	0	NUT M10	
31241080	31241080	0	HEXAGON SELFLOCK NUT M8	
31312080	31312080	0	STUD BOLT M8X46X20X12	
31312102	31312102	0	STUD BOLT M10X40X24X12	
31411084	31411084	0	WASHER 8,4x17	
31423084	31423084	0	SPRING WASHER 8,4	
31423105	31423105	0	SPRING WASHER 10,5	
35111047	35111047	0	SEEGER RING	
37111202	37111202	0	BEARING	
37111253	37111253	0	BEARING	
38111400	38111400	0	O-RING	
38213002	38213002	0	OIL SEAL 30X40X7	
52443852	52443852	0	AXLE SHAFT	
52443853	52443853	0	AXLE SHAFT	
52448182	52448182	0	COUPLING	
53243851	53243851	0	HUB	
56143865	56143865	0	RING	
56143880	56143880	0	SMALL LEVER	
56143883	56143883	0	STOP	
56443857	56443857	0	SPACER	
56443871	56443871	0	ROD	
58002429	58002429	0	CLAMPING SCREW	
58042167	58042167	0	SHEATH TERMINAL	
58043855	58043855	0	GASKET	
58043874	58043874	0	SPRING	
58043881	58043881	0	SPRING	
59248490	59248490	0	DIFFERENTIAL GEAR	

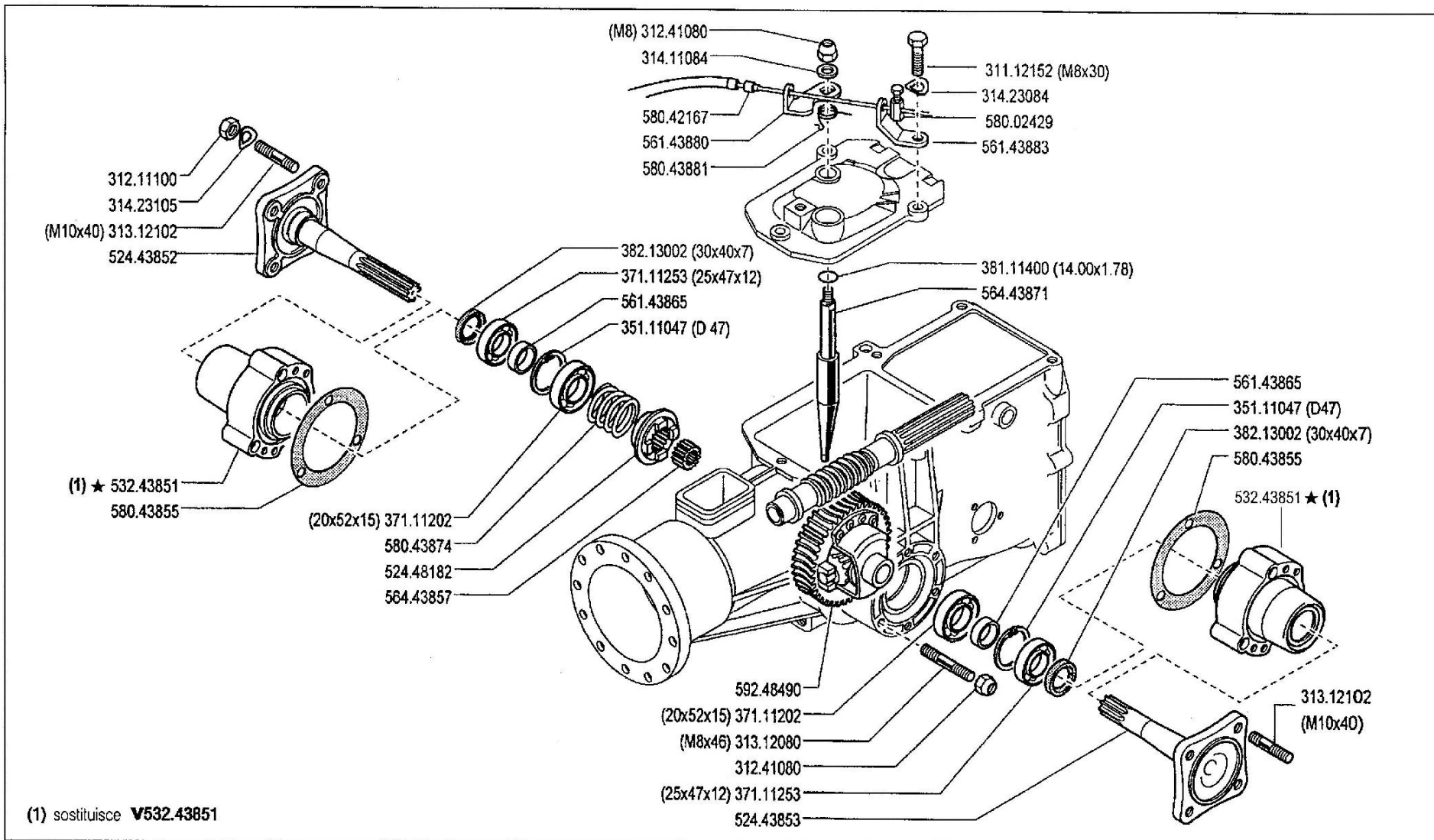

(1) sostituisce **V532.43851**

FERRARI

500 serie **95**

DIFFERENZIALE (530)

DIFFERENTIAL
DIFFERENCIAL

DIFFERENTIEL
DIFFERENTIAL

DALLA MACCHINA
DE LA MAQUINA
DE LA MACHINE
FROM THE MACHINE
AB DER MASCHINE

AGGIORNAMENTO
APLAZAMIENTO
MISE A JOUR
REVISION
ANPASSUNG

06

Rev.
1

5/2000

★N

ZENIT

Pos.	Code	Q.ty	Description	Notes
31112152	31112152	0	SCREW TE M8X30 UNI 5739 8G	
31211100	31211100	0	NUT M10	
31241080	31241080	0	HEXAGON SELFLOCK NUT M8	
31312080	31312080	0	STUD BOLT M8X46X20X12	
31312102	31312102	0	STUD BOLT M10X40X24X12	
31411084	31411084	0	WASHER 8,4x17	
31423084	31423084	0	SPRING WASHER 8,4	
31423105	31423105	0	SPRING WASHER 10,5	
35111047	35111047	0	SEEGER RING	
37111202	37111202	0	BEARING	
37111253	37111253	0	BEARING	
38111400	38111400	0	O-RING	
38213002	38213002	0	OIL SEAL 30X40X7	
52443852	52443852	0	AXLE SHAFT	
52443853	52443853	0	AXLE SHAFT	
52448182	52448182	0	COUPLING	
53243851	53243851	0	HUB	
56143865	56143865	0	RING	
56143880	56143880	0	SMALL LEVER	
56143883	56143883	0	STOP	
56443857	56443857	0	SPACER	
56443871	56443871	0	ROD	
58043855	58043855	0	GASKET	
58043874	58043874	0	SPRING	
58043881	58043881	0	SPRING	
59248490	59248490	0	DIFFERENTIAL GEAR	

520 - 530

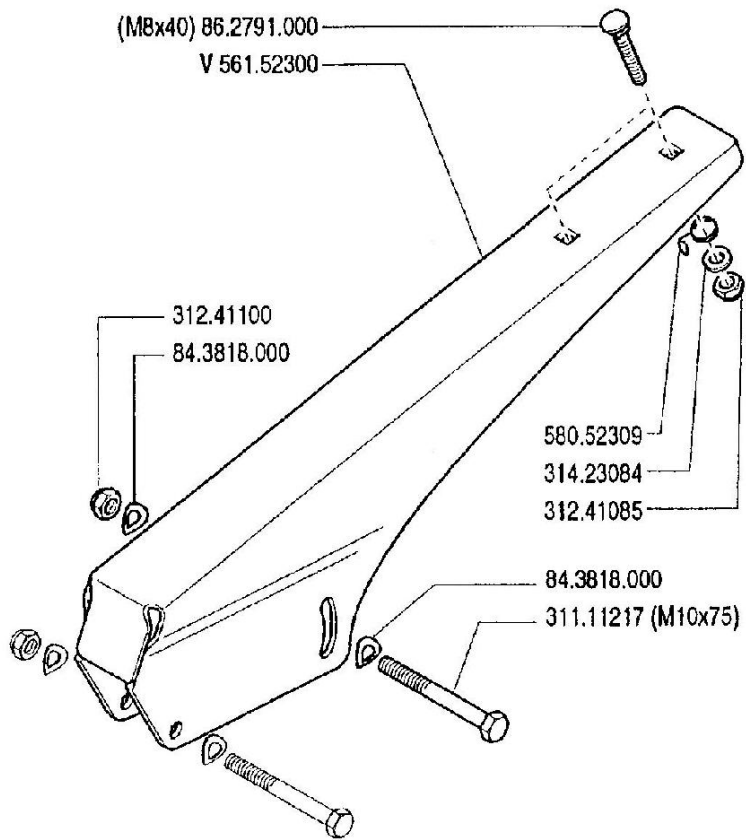

500

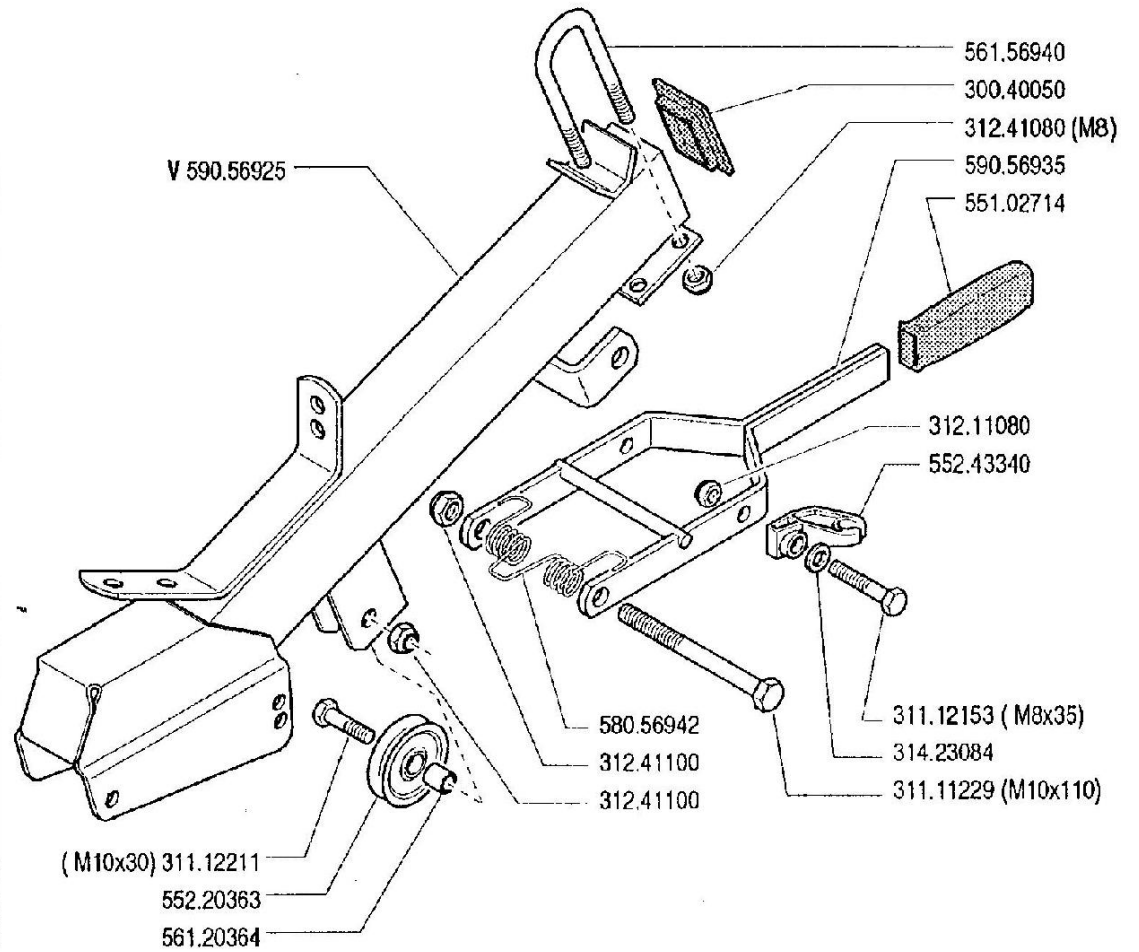

V = verde - vert - green - grün

FERRARI

500 serie **95**

COLUMNA
PLANTON

PIANTONE

STEERING COLUMN
LENKSÄULE

DALLA MACCHINA
DE LA MAQUINA
DE LA MACHINE
FROM THE MACHINE
AB DER MASCHINE

N.

07.00

01.06.1995

Pos.	Code	Q.ty	Description	Notes
30040050	30040050	0	RECTANGULAR TERMINAL 50X40	
31111217	31111217	0	SCREW TE M10X75 UNI 5737 8G	
31111229	31111229	0	SCREW TE M10X110 UNI 5737 8G	
31112153	31112153	0	SCREW TE M8X35 UNI 5739 8G	
31112211	31112211	0	SCREW TE M10X30 UNI 5739	
31211080	31211080	0	NUT M8	
31241080	31241080	0	HEXAGON SELFLOCK NUT M8	
31241085	31241085	0	SELFLOCK NUT M8 6S	
31241100	31241100	0	SELFLOCK HEXAGON NUT M10	
31423084	31423084	0	SPRING WASHER 8,4	
55102714	55102714	0	KNOB	
55220363	55220363	0	PULLEY	
55243340	55243340	0	SUPPORT	
56120364	56120364	0	SLEEVE	
56152300	56152300	0	STEER.COLUMN MF	
56156940	56156940	0	U BOLT	
58052309	58052309	0	SOSTEGNO GUAINA MF	
58056942	58056942	0	SPRING	
59056925	59056925	0	COLUMN	
59056935	59056935	0	LEVER	
86279100	862791000	0		
F0843818	F0843818000	0	WASHER 11x30/2,5	
F0862791	F0862791000	0	VITE M8X40 UNI 5737 CL:8.8 ▫	

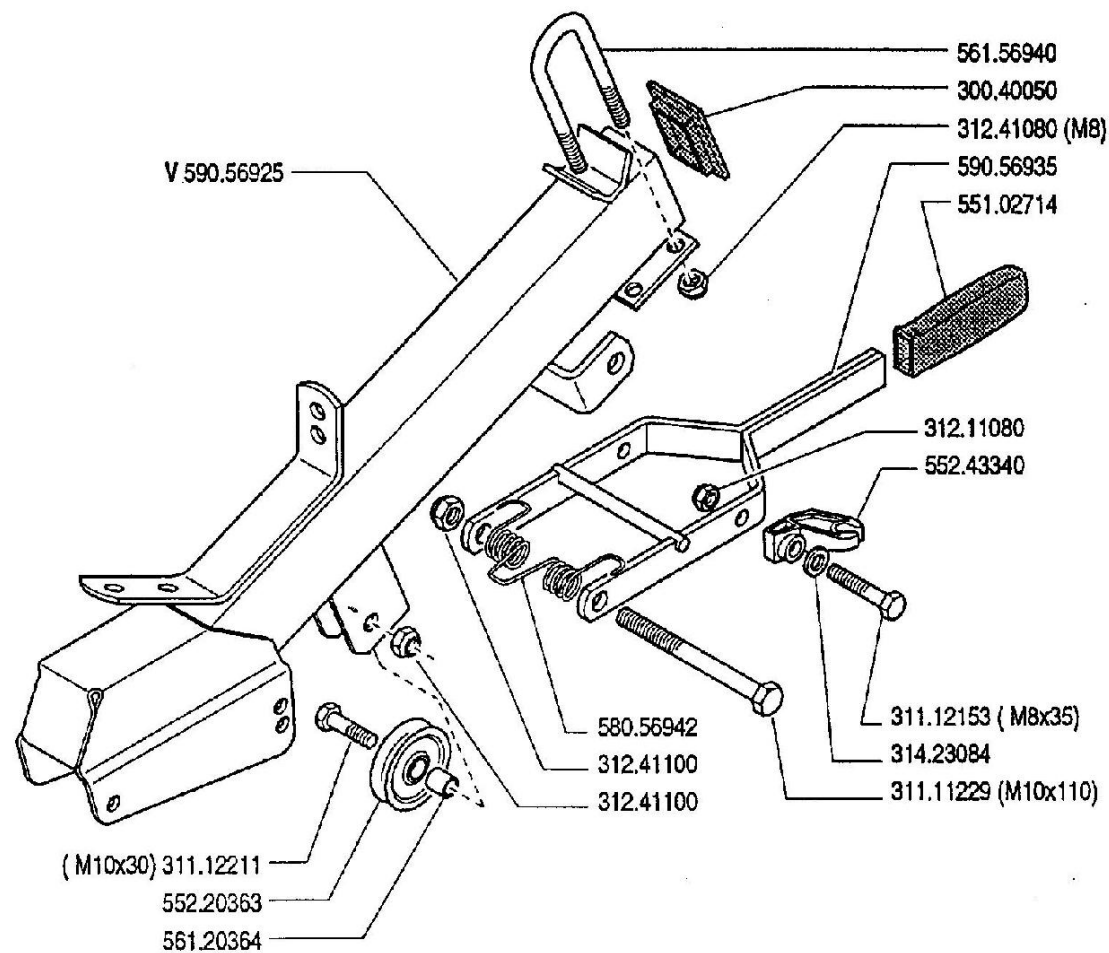

V = verde - vert - green - grün

PIANTONE (500 - 520 - 530)

COLUMNA
PLANTON

STEERING COLUMN
LENKSÄULE

DALLA MACCHINA
DE LA MAQUINA
DE LA MACHINE
FROM THE MACHINE
AB DER MASCHINE

★ N.

07.01

21631 (530)

155330 (520)

02.09.1996

FERRARI

500 serie 95

Pos.	Code	Q.ty	Description	Notes
30040050	30040050	0	RECTANGULAR TERMINAL 50X40	
31111229	31111229	0	SCREW TE M10X110 UNI 5737 8G	
31112153	31112153	0	SCREW TE M8X35 UNI 5739 8G	
31112211	31112211	0	SCREW TE M10X30 UNI 5739	
31211080	31211080	0	NUT M8	
31241080	31241080	0	HEXAGON SELFLOCK NUT M8	
31241100	31241100	0	SELFLOCK HEXAGON NUT M10	
31423084	31423084	0	SPRING WASHER 8,4	
55102714	55102714	0	KNOB	
55220363	55220363	0	PULLEY	
55243340	55243340	0	SUPPORT	
56120364	56120364	0	SLEEVE	
56156940	56156940	0	U BOLT	
58056942	58056942	0	SPRING	
59056925	59056925	0	COLUMN	
59056935	59056935	0	LEVER	

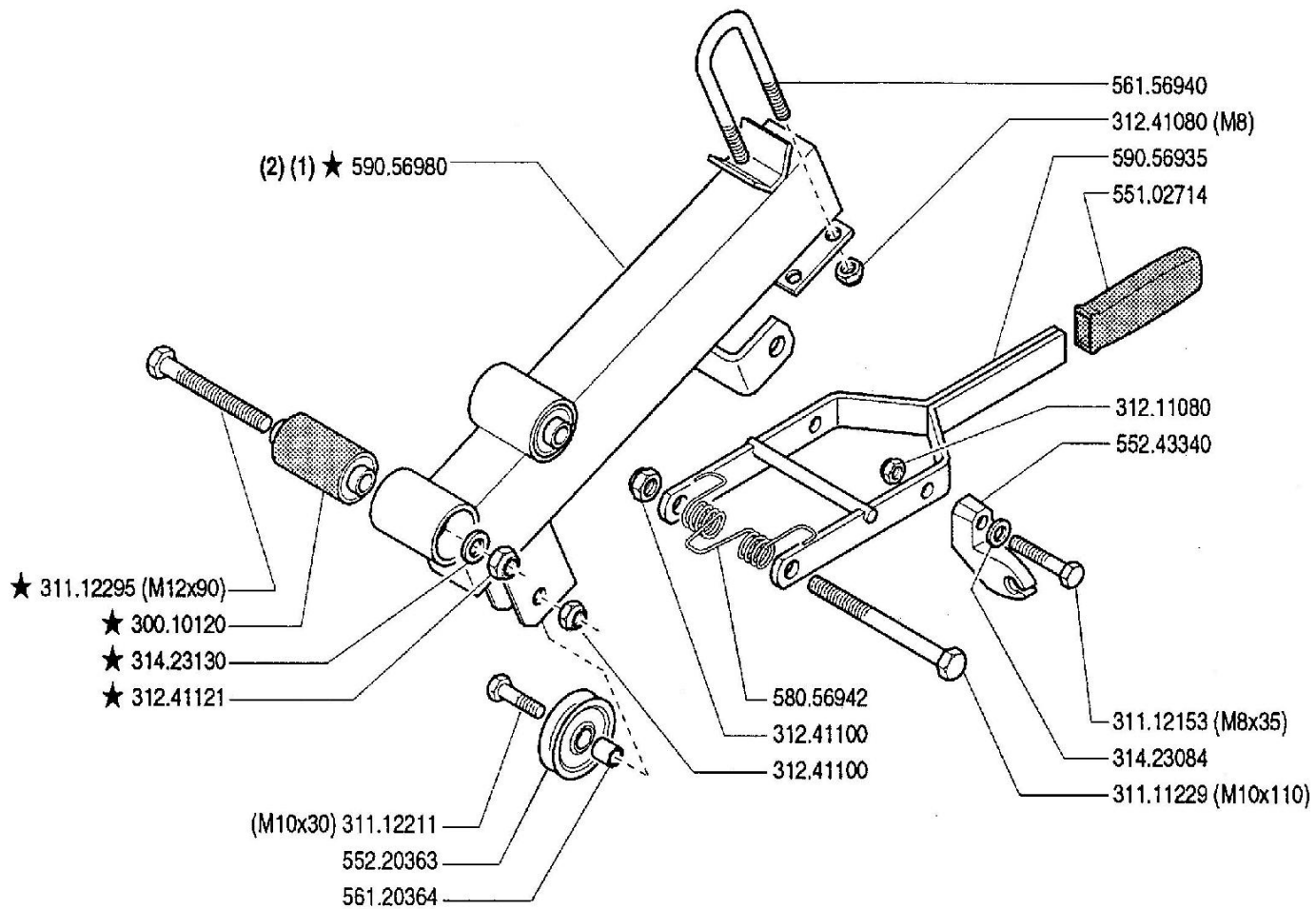

(1) (520 - 530) { tav. 07.02 }
 (2) (500) { tav. 01.02 } sostituisce 590.56925
 { tav. 09.02 }

FERRARI

500 serie **95**

PIANTONE (500-510-520-530)

STEERING COLUMN
COLUMNNA

PLANTON
LENKSÄULE

DALLA MACCHINA
DE LA MAQUINA
DE LA MACHINE
FROM THE MACHINE
AB DER MASCHINE

★N.

22690 (530)

158833 (520)

80952 (500)

07 **02**

9/1997

Mod

ZENNE

Pos.	Code	Q.ty	Description	Notes
30010120	30010120	0	SILENT-BLOCK 12X40X58X66	
31111229	31111229	0	SCREW TE M10X110 UNI 5737 8G	
31112153	31112153	0	SCREW TE M8X35 UNI 5739 8G	
31112211	31112211	0	SCREW TE M10X30 UNI 5739	
31112295	31112295	0	SCREW TE M12X90 UNI 5737	
31211080	31211080	0	NUT M8	
31241080	31241080	0	HEXAGON SELFLOCK NUT M8	
31241100	31241100	0	SELFLOCK HEXAGON NUT M10	
31241121	31241121	0	SELFLOCK NUT M12	
31423084	31423084	0	SPRING WASHER 8,4	
31423130	31423130	0	SPRING WASHER 13	
55102714	55102714	0	KNOB	
55220363	55220363	0	PULLEY	
55243340	55243340	0	SUPPORT	
56120364	56120364	0	SLEEVE	
56156940	56156940	0	U BOLT	
58056942	58056942	0	SPRING	
59056935	59056935	0	LEVER	
59056980	59056980	0	COLUMN	

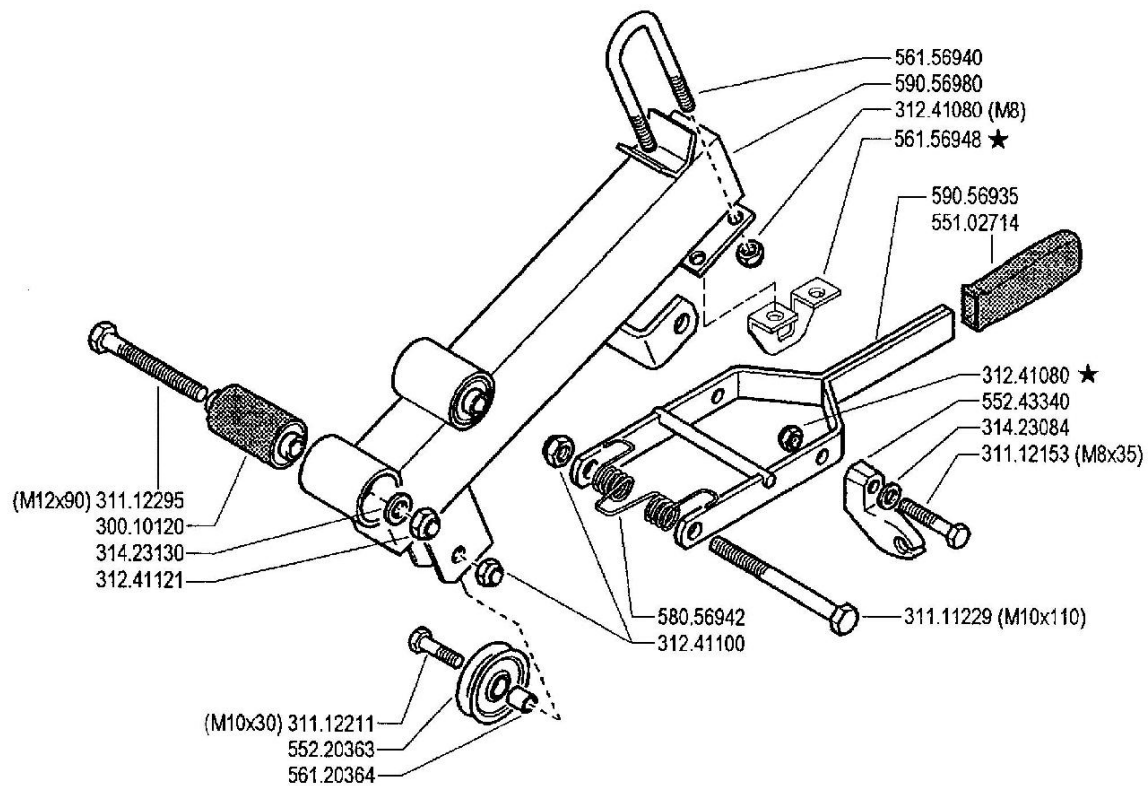

FERRARI

500 serie **95**

PIANTONE (500 - 510 - 520 - 530 - 530S - 530S2)

STEERING COLUMN
COLUMNNA

PLANTON
LENKSÄULE

DALLA MACCHINA
DE LA MAQUINA
DE LA MACHINE
FROM THE MACHINE
AB DER MASCHINE

★N

AGGIORNAMENTO
REVISION
MISE A JOUR
APLAZAMIENTO
ANPASSUNG

07

Rev.
3

12/2002

ZENNE

Pos.	Code	Q.ty	Description	Notes
30010120	30010120	0	SILENT-BLOCK 12X40X58X66	
31111229	31111229	0	SCREW TE M10X110 UNI 5737 8G	
31112153	31112153	0	SCREW TE M8X35 UNI 5739 8G	
31112211	31112211	0	SCREW TE M10X30 UNI 5739	
31112295	31112295	0	SCREW TE M12X90 UNI 5737	
31241080	31241080	0	HEXAGON SELFLOCK NUT M8	
31241100	31241100	0	SELFLOCK HEXAGON NUT M10	
31241121	31241121	0	SELFLOCK NUT M12	
31423084	31423084	0	SPRING WASHER 8,4	
31423130	31423130	0	SPRING WASHER 13	
55102714	55102714	0	KNOB	
55220363	55220363	0	PULLEY	
55243340	55243340	0	SUPPORT	
56120364	56120364	0	SLEEVE	
56156940	56156940	0	U BOLT	
56156948	56156948	0	STOP	
58056942	58056942	0	SPRING	
59056935	59056935	0	LEVER	
59056980	59056980	0	COLUMN	

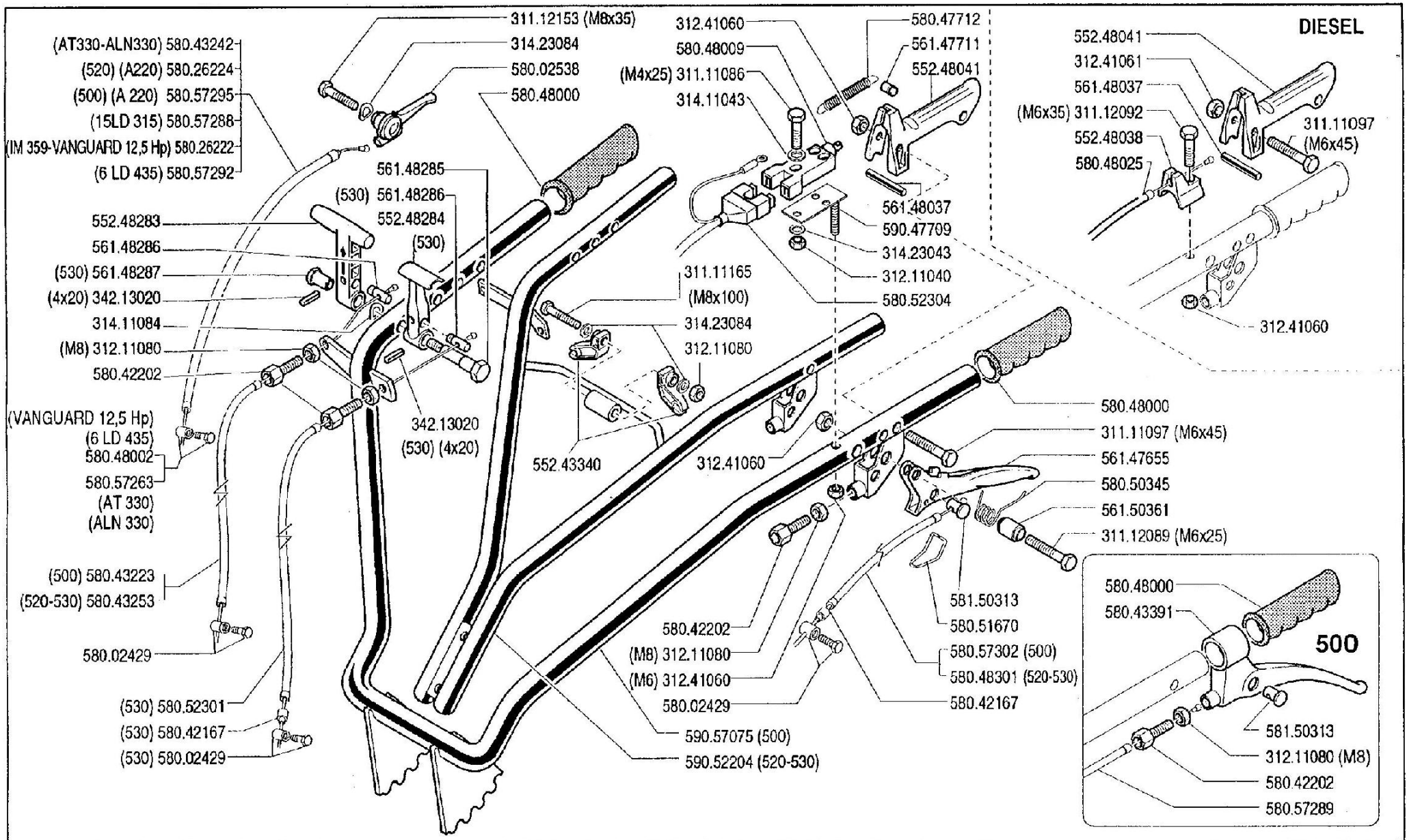

FERRARI

500 serie **95**

MANUBRIO

MANILLAR
MANCHERON

HANDLEBAR
LENKER

DALLA MACCHINA
DE LA MAQUINA
DE LA MACHINE
FROM THE MACHINE
AB DER MASCHINE

N.

08.00

01.06.1995

Pos.	Code	Q.ty	Description	Notes
31111086	31111086	0	SCREW TE M4X25 UNI 5739 8G	
31111097	31111097	0	SCREW TE M6X45 UNI 5737 8G	
31111165	31111165	0	SCREW TE M8X100 UNI 5737 8G	
31112089	31112089	0	SCREW TE M6X25 UNI 5739 8G	
31112092	31112092	0	SCREW TE M6X35 UNI 5739 8G	
31112153	31112153	0	SCREW TE M8X35 UNI 5739 8G	
31211040	31211040	0	NUT M4	
31211080	31211080	0	NUT M8	
31241060	31241060	0	HEXAGON SELFLOCK NUT M6	
31241061	31241061	0	SELFLOCK NUT M6 6S	
31411043	31411043	0	WASHER 4,3X9	
31411084	31411084	0	WASHER 8,4x17	
31423043	31423043	0	SPRING WASHER 4,3	
31423084	31423084	0	SPRING WASHER 8,4	
34213020	34213020	0	ROLL PIN	
55243340	55243340	0	SUPPORT	
55248038	55248038	0	STOP	
55248041	55248041	0	LEVER	
55248283	55248283	0	COMMAND LEVER	
55248284	55248284	0	LEVER	
56147655	56147655	0	CLUTCH LEVER	
56147711	56147711	0	PIN	
56148037	56148037	0	LEVER STOP	
56148285	56148285	0	PIN	
56148286	56148286	0	PIN	
56148287	56148287	0	STUD BOLT	
56150361	56150361	0	SPACER	
58002429	58002429	0	CLAMPING SCREW	
58002538	58002538	0	COMMAND LEVER	
58026222	58026222	0	LINE AND SHEATH	
58026224	58026224	0	LINE AND SHEATH	
58042167	58042167	0	SHEATH TERMINAL	
58042202	58042202	0	ADJUSTING SCREW	
58043223	58043223	0	LINE AND SHEATH	

SERIAL

008_00 - HANDLEBAR

CODE REV

008_0_13197

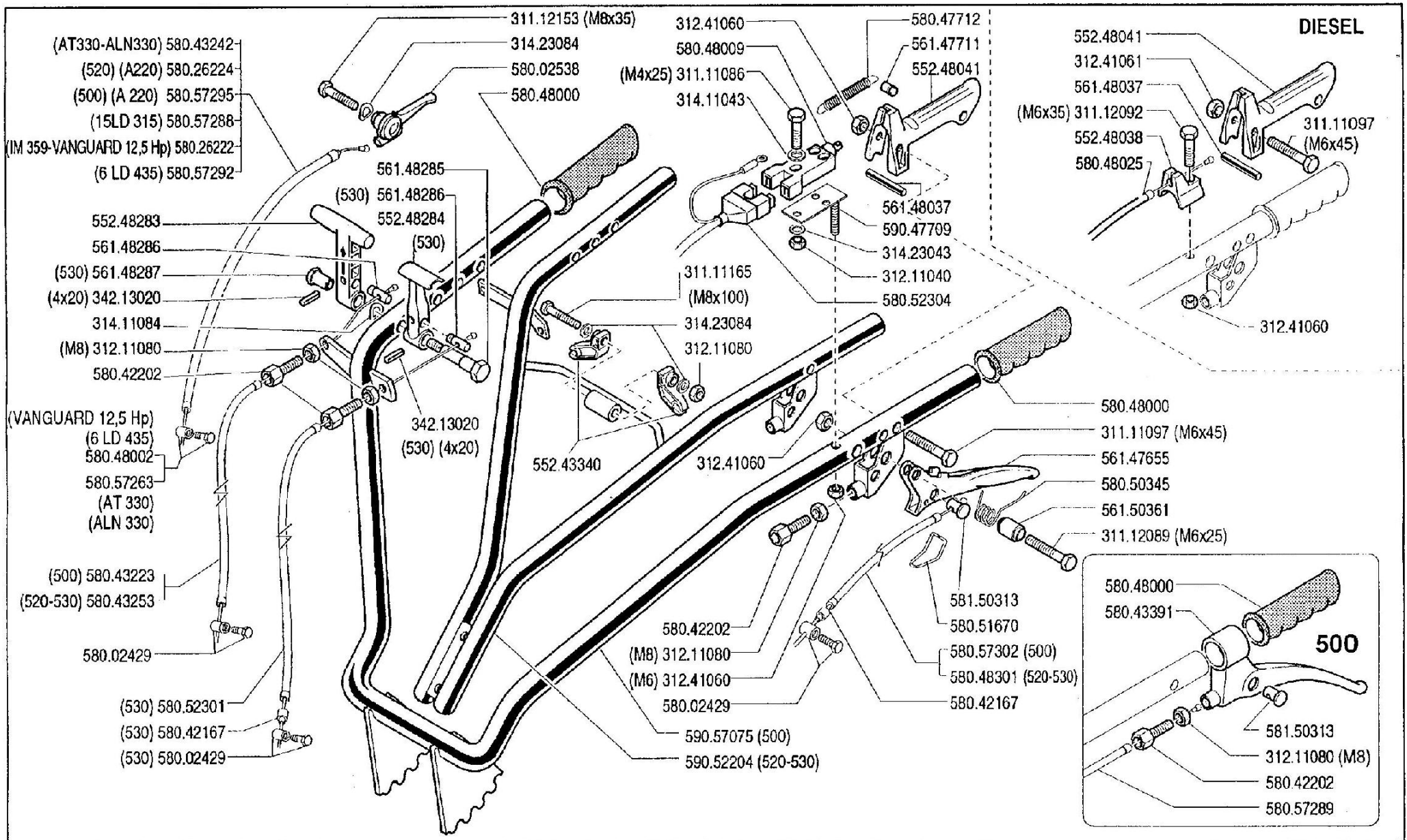

FERRARI

500 serie **95**

MANUBRIO

MANILLAR
 MANCHERON

HANDLEBAR
 LENKER

DALLA MACCHINA
 DE LA MAQUINA
 DE LA MACHINE
 FROM THE MACHINE
 AB DER MASCHINE

N.

08.00

01.06.1995

Pos.	Code	Q.ty	Description	Notes
58043242	58043242	0	LINE AND SHEATH	
58043253	58043253	0	LINE AND SHEATH	
58043391	58043391	0	LEVER	
58047712	58047712	0	SPRING	
58048000	58048000	0	KNOB	
58048002	58048002	0	CLAMPING SCREW	
58048009	58048009	0	SWITCH	
58048025	58048025	0	LINE AND SHEATH	
58048301	58048301	0	LINE AND SHEATH	
58050345	58050345	0	SPRING	
58051670	58051670	0	CLEVIS	
58052301	58052301	0	LINE AND SHEATH	
58052304	58052304	0	WIRING	
58057263	58057263	0	CLAMPING SCREW	
58057288	58057288	0	LINE AND SHEATH	
58057289	58057289	0	LINE AND SHEATH	
58057292	58057292	0	LINE AND SHEATH	
58057295	58057295	0	LINE AND SHEATH	
58057302	58057302	0	LINE AND SHEATH	
58150313	58150313	0	CABLE CLAMP	
59047709	59047709	0	SWITCH SUPPORT	
59052204	59052204	0	COMPLETE HANDLE BAR	
59057075	59057075	0	COMPLETE HANDLE BAR	

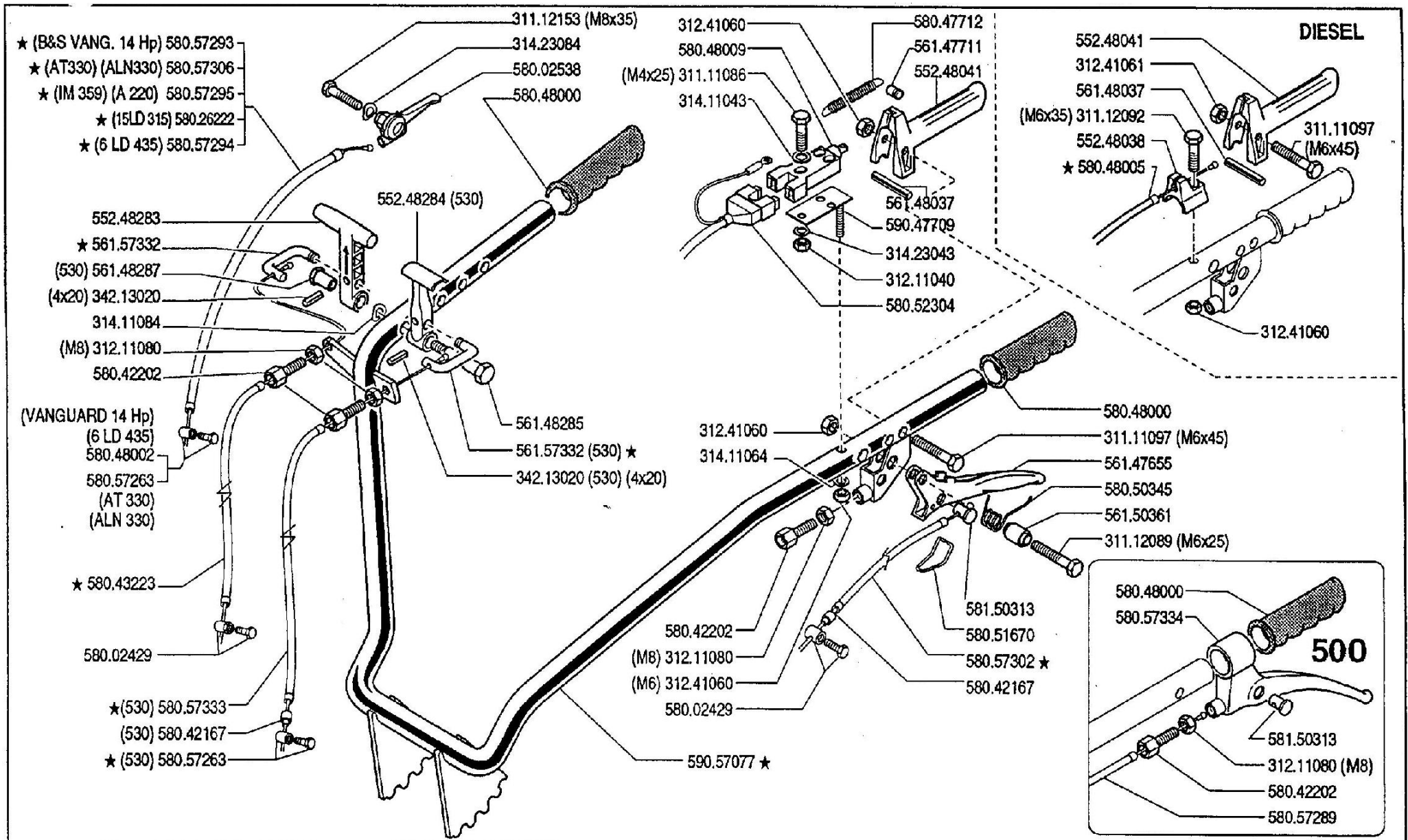

	500 serie 95	MANUBRIO		DALLA MACCHINA DE LA MAQUINA DE LA MACHINE FROM THE MACHINE AB DER MASCHINE	21832 (530) 156401 (520) 80724 (500)	08.01 02.09.1996
		MANILLAR	HANDLEBAR			
		MANCHERON	LENKER			
		★ N.				

Pos.	Code	Q.ty	Description	Notes
31111086	31111086	0	SCREW TE M4X25 UNI 5739 8G	
31111097	31111097	0	SCREW TE M6X45 UNI 5737 8G	
31112089	31112089	0	SCREW TE M6X25 UNI 5739 8G	
31112092	31112092	0	SCREW TE M6X35 UNI 5739 8G	
31112153	31112153	0	SCREW TE M8X35 UNI 5739 8G	
31211040	31211040	0	NUT M4	
31211080	31211080	0	NUT M8	
31241060	31241060	0	HEXAGON SELFLOCK NUT M6	
31241061	31241061	0	SELFLOCK NUT M6 6S	
31411043	31411043	0	WASHER 4,3X9	
31411064	31411064	0	WASHER 6,4x12,5	
31411084	31411084	0	WASHER 8,4x17	
31423043	31423043	0	SPRING WASHER 4,3	
31423084	31423084	0	SPRING WASHER 8,4	
34213020	34213020	0	ROLL PIN	
55248038	55248038	0	STOP	
55248041	55248041	0	LEVER	
55248283	55248283	0	COMMAND LEVER	
55248284	55248284	0	LEVER	
56147655	56147655	0	CLUTCH LEVER	
56147711	56147711	0	PIN	
56148037	56148037	0	LEVER STOP	
56148285	56148285	0	PIN	
56148287	56148287	0	STUD BOLT	
56150361	56150361	0	SPACER	
56157332	56157332	0	U BOLT	
58002429	58002429	0	CLAMPING SCREW	
58002538	58002538	0	COMMAND LEVER	
58026222	58026222	0	LINE AND SHEATH	
58042167	58042167	0	SHEATH TERMINAL	
58042202	58042202	0	ADJUSTING SCREW	
58043223	58043223	0	LINE AND SHEATH	
58047712	58047712	0	SPRING	
58048000	58048000	0	KNOB	

SERIAL

008_01 - HANDLEBAR

Version: MF 520, MF 530, MF 500

CODE REV

008_1_13255

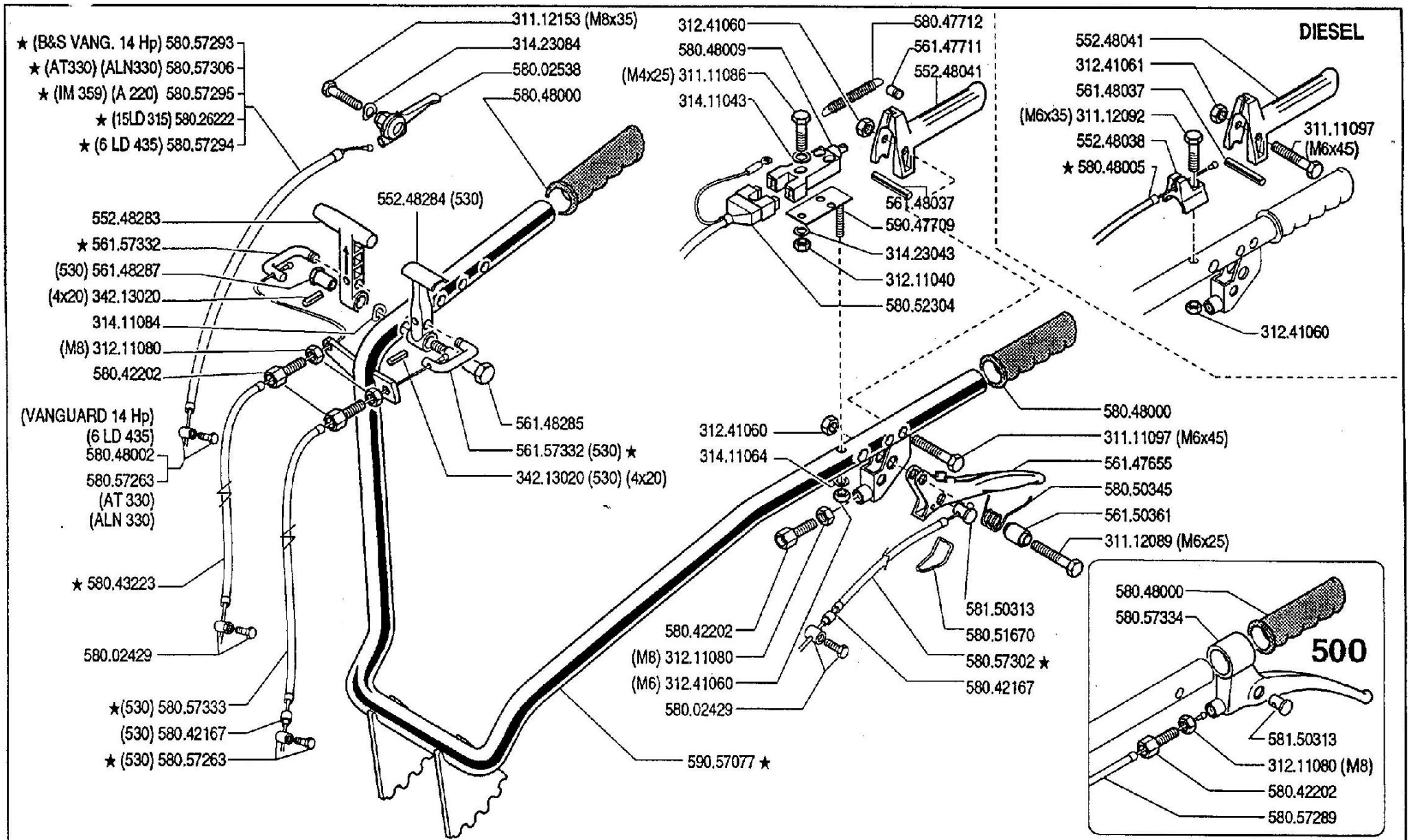

	500 serie 95	MANUBRIO		DALLA MACCHINA DE LA MAQUINA DE LA MACHINE FROM THE MACHINE AB DER MASCHINE	<div style="text-align: right; font-size: 2em; font-weight: bold;">08.01</div>	
		MANILLAR	HANDLEBAR			21832 (530)
		MANCHERON	LENKER			156401 (520)
						★ N. 80724 (500)
					02.09.1996	

Pos.	Code	Q.ty	Description	Notes
58048002	58048002	0	CLAMPING SCREW	
58048005	58048005	0	LINE AND SHEATH	
58048009	58048009	0	SWITCH	
58050345	58050345	0	SPRING	
58051670	58051670	0	CLEVIS	
58052304	58052304	0	WIRING	
58057263	58057263	0	CLAMPING SCREW	
58057289	58057289	0	LINE AND SHEATH	
58057293	58057293	0	LINE AND SHEATH	
58057294	58057294	0	LINE AND SHEATH	
58057295	58057295	0	LINE AND SHEATH	
58057302	58057302	0	LINE AND SHEATH	
58057306	58057306	0	LINE AND SHEATH	
58057333	58057333	0	LINE AND SHEATH	
58057334	58057334	0	LEVER	
58150313	58150313	0	CABLE CLAMP	
59047709	59047709	0	SWITCH SUPPORT	
59057077	59057077	0	COMPLETE HANDLE BAR	

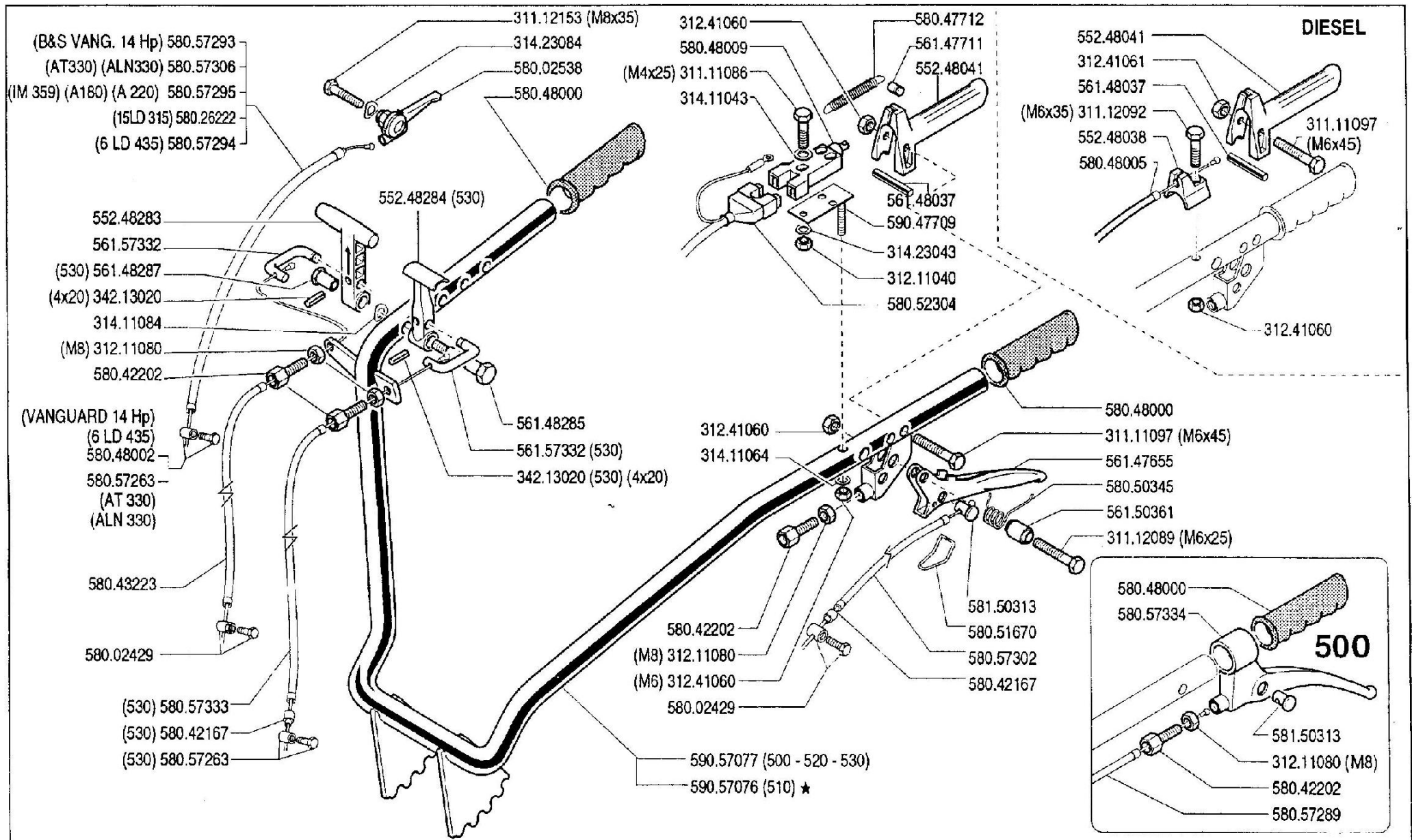

FERRARI

500 serie 95

MANUBRIO

MANILLAR
MANCHERON

HANDLEBAR
LENKER

DALLA MACCHINA
DE LA MAQUINA
DE LA MACHINE
FROM THE MACHINE
AB DER MASCHINE

AGGIORNAMENTO
REVISION
MISE A JOUR
APLAZAMIENTO
ANPASSUNG

08.02

9/1997

★ N.

Pos.	Code	Q.ty	Description	Notes
31111086	31111086	0	SCREW TE M4X25 UNI 5739 8G	
31111097	31111097	0	SCREW TE M6X45 UNI 5737 8G	
31112089	31112089	0	SCREW TE M6X25 UNI 5739 8G	
31112092	31112092	0	SCREW TE M6X35 UNI 5739 8G	
31112153	31112153	0	SCREW TE M8X35 UNI 5739 8G	
31211040	31211040	0	NUT M4	
31211080	31211080	0	NUT M8	
31241060	31241060	0	HEXAGON SELFLOCK NUT M6	
31241061	31241061	0	SELFLOCK NUT M6 6S	
31411043	31411043	0	WASHER 4,3X9	
31411064	31411064	0	WASHER 6,4x12,5	
31411084	31411084	0	WASHER 8,4x17	
31423043	31423043	0	SPRING WASHER 4,3	
31423084	31423084	0	SPRING WASHER 8,4	
34213020	34213020	0	ROLL PIN	
55248038	55248038	0	STOP	
55248041	55248041	0	LEVER	
55248283	55248283	0	COMMAND LEVER	
55248284	55248284	0	LEVER	
56147655	56147655	0	CLUTCH LEVER	
56147711	56147711	0	PIN	
56148037	56148037	0	LEVER STOP	
56148285	56148285	0	PIN	
56148287	56148287	0	STUD BOLT	
56150361	56150361	0	SPACER	
56157332	56157332	0	U BOLT	
58002429	58002429	0	CLAMPING SCREW	
58002538	58002538	0	COMMAND LEVER	
58026222	58026222	0	LINE AND SHEATH	
58042167	58042167	0	SHEATH TERMINAL	
58042202	58042202	0	ADJUSTING SCREW	
58043223	58043223	0	LINE AND SHEATH	
58047712	58047712	0	SPRING	
58048000	58048000	0	KNOB	

SERIAL

008_02 - HANDLEBAR

CODE REV

008_2_13308

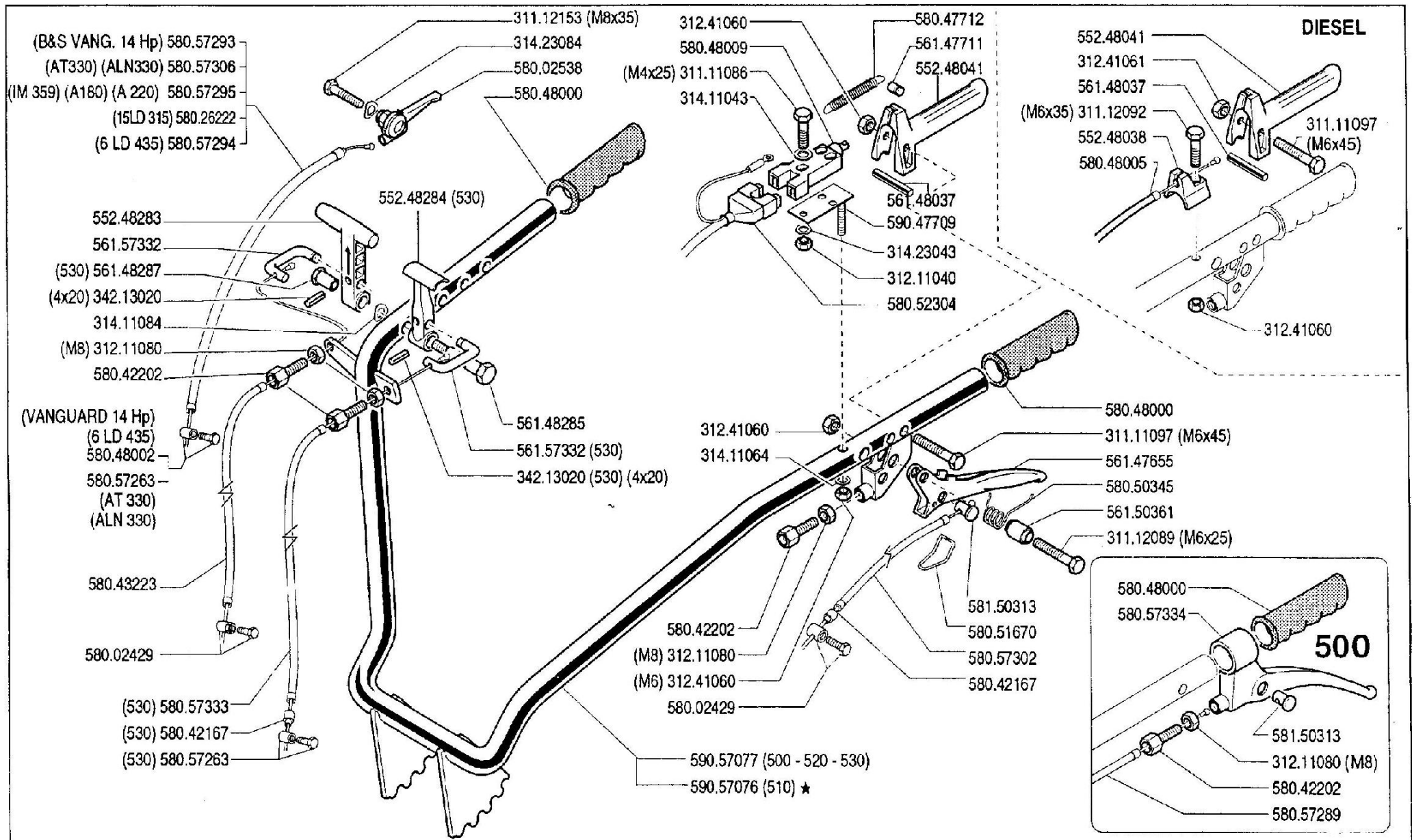

FERRARI

500 serie 95

MANUBRIO

MANILLAR
MANCHERON

HANDLEBAR
LENKER

DALLA MACCHINA
DE LA MAQUINA
DE LA MACHINE
FROM THE MACHINE
AB DER MASCHINE

AGGIORNAMENTO
REVISION
MISE A JOUR
APLAZAMIENTO
ANPASSUNG

08.02

9/1997

★ N.

Pos.	Code	Q.ty	Description	Notes
58048002	58048002	0	CLAMPING SCREW	
58048005	58048005	0	LINE AND SHEATH	
58048009	58048009	0	SWITCH	
58050345	58050345	0	SPRING	
58051670	58051670	0	CLEVIS	
58052304	58052304	0	WIRING	
58057263	58057263	0	CLAMPING SCREW	
58057289	58057289	0	LINE AND SHEATH	
58057293	58057293	0	LINE AND SHEATH	
58057294	58057294	0	LINE AND SHEATH	
58057295	58057295	0	LINE AND SHEATH	
58057302	58057302	0	LINE AND SHEATH	
58057306	58057306	0	LINE AND SHEATH	
58057333	58057333	0	LINE AND SHEATH	
58057334	58057334	0	LEVER	
58150313	58150313	0	CABLE CLAMP	
59047709	59047709	0	SWITCH SUPPORT	
59057076	59057076	0	COMPLETE HANDLE BAR	
59057077	59057077	0	COMPLETE HANDLE BAR	

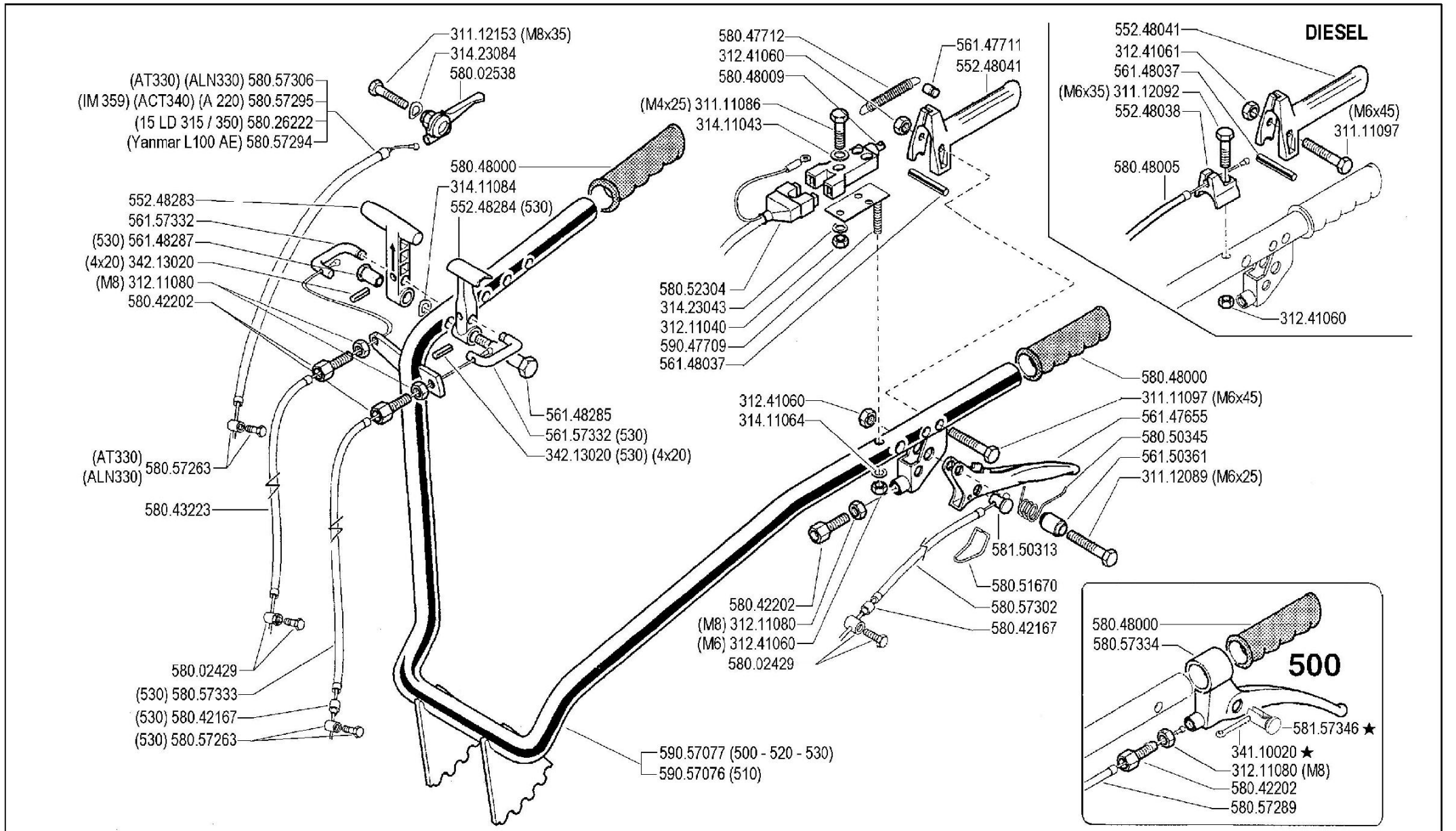

FERRARI

500 serie 95

MANUBRIO (500 - 510 - 520 - 530)

HANDLEBAR
MANILLAR

MANCHERON
LENKER

DALLA MACCHINA
DE LA MAGUINA
DE LA MACHINE
FROM THE MACHINE
AB DER MASCHINE

AGGIORNAMENTO

REVISION

MISE A JOUR

APLAZAMIENTO

ANPASSUNG

08

Mod
03

★N.

1/2000

ZENIT

Pos.	Code	Q.ty	Description	Notes
31111086	31111086	0	SCREW TE M4X25 UNI 5739 8G	
31111097	31111097	0	SCREW TE M6X45 UNI 5737 8G	
31112089	31112089	0	SCREW TE M6X25 UNI 5739 8G	
31112092	31112092	0	SCREW TE M6X35 UNI 5739 8G	
31112153	31112153	0	SCREW TE M8X35 UNI 5739 8G	
31211040	31211040	0	NUT M4	
31211080	31211080	0	NUT M8	
31241060	31241060	0	HEXAGON SELFLOCK NUT M6	
31241061	31241061	0	SELFLOCK NUT M6 6S	
31411043	31411043	0	WASHER 4,3X9	
31411064	31411064	0	WASHER 6,4x12,5	
31411084	31411084	0	WASHER 8,4x17	
31423043	31423043	0	SPRING WASHER 4,3	
31423084	31423084	0	SPRING WASHER 8,4	
34110020	34110020	0	SPLIT PIN	
34213020	34213020	0	ROLL PIN	
55248038	55248038	0	STOP	
55248041	55248041	0	LEVER	
55248283	55248283	0	COMMAND LEVER	
55248284	55248284	0	LEVER	
56147655	56147655	0	CLUTCH LEVER	
56147711	56147711	0	PIN	
56148037	56148037	0	LEVER STOP	
56148285	56148285	0	PIN	
56148287	56148287	0	STUD BOLT	
56150361	56150361	0	SPACER	
56157332	56157332	0	U BOLT	
58002429	58002429	0	CLAMPING SCREW	
58002538	58002538	0	COMMAND LEVER	
58026222	58026222	0	LINE AND SHEATH	
58042167	58042167	0	SHEATH TERMINAL	
58042202	58042202	0	ADJUSTING SCREW	
58043223	58043223	0	LINE AND SHEATH	
58047712	58047712	0	SPRING	

SERIAL

008_03 - HANDLEBAR (500-510-520-530)

CODE REV

008_3_13362

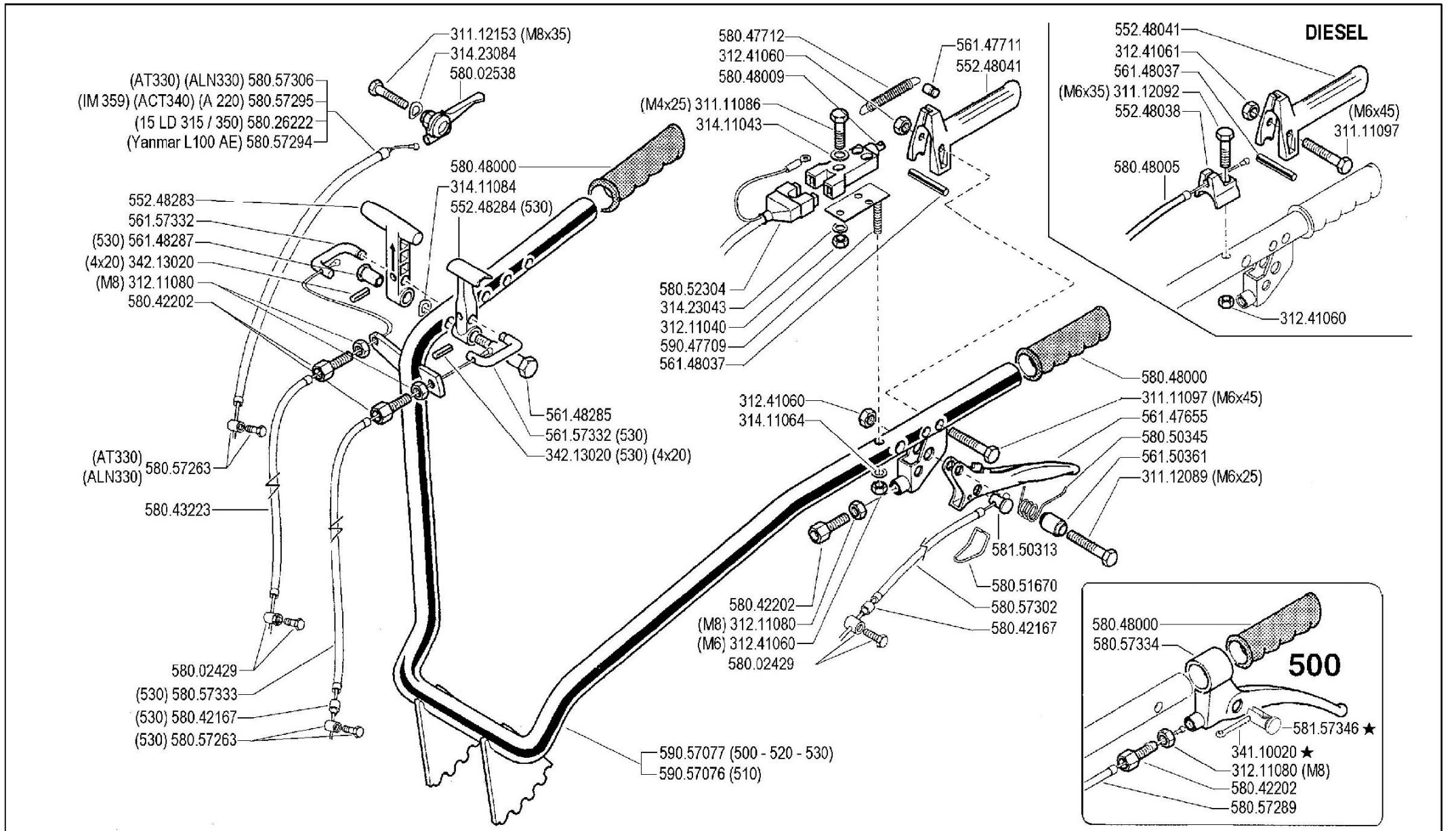

FERRARI

500 serie 95

MANUBRIO (500 - 510 - 520 - 530)

HANDLEBAR
MANILLAR

MANCHERON
LENKER

DALLA MACCHINA
DE LA MAGUINA
DE LA MACHINE
FROM THE MACHINE
AB DER MASCHINE

AGGIORNAMENTO

REVISION

MISE A JOUR

APLAZAMIENTO

ANPASSUNG

08

Mod
03

★N.

1/2000

ZENIT

Pos.	Code	Q.ty	Description	Notes
58048000	58048000	0	KNOB	
58048005	58048005	0	LINE AND SHEATH	
58048009	58048009	0	SWITCH	
58050345	58050345	0	SPRING	
58051670	58051670	0	CLEVIS	
58052304	58052304	0	WIRING	
58057263	58057263	0	CLAMPING SCREW	
58057289	58057289	0	LINE AND SHEATH	
58057294	58057294	0	LINE AND SHEATH	
58057295	58057295	0	LINE AND SHEATH	
58057302	58057302	0	LINE AND SHEATH	
58057306	58057306	0	LINE AND SHEATH	
58057333	58057333	0	LINE AND SHEATH	
58057334	58057334	0	LEVER	
58150313	58150313	0	CABLE CLAMP	
58157346	58157346	0	CABLE CLAMP	
59047709	59047709	0	SWITCH SUPPORT	
59057076	59057076	0	COMPLETE HANDLE BAR	
59057077	59057077	0	COMPLETE HANDLE BAR	

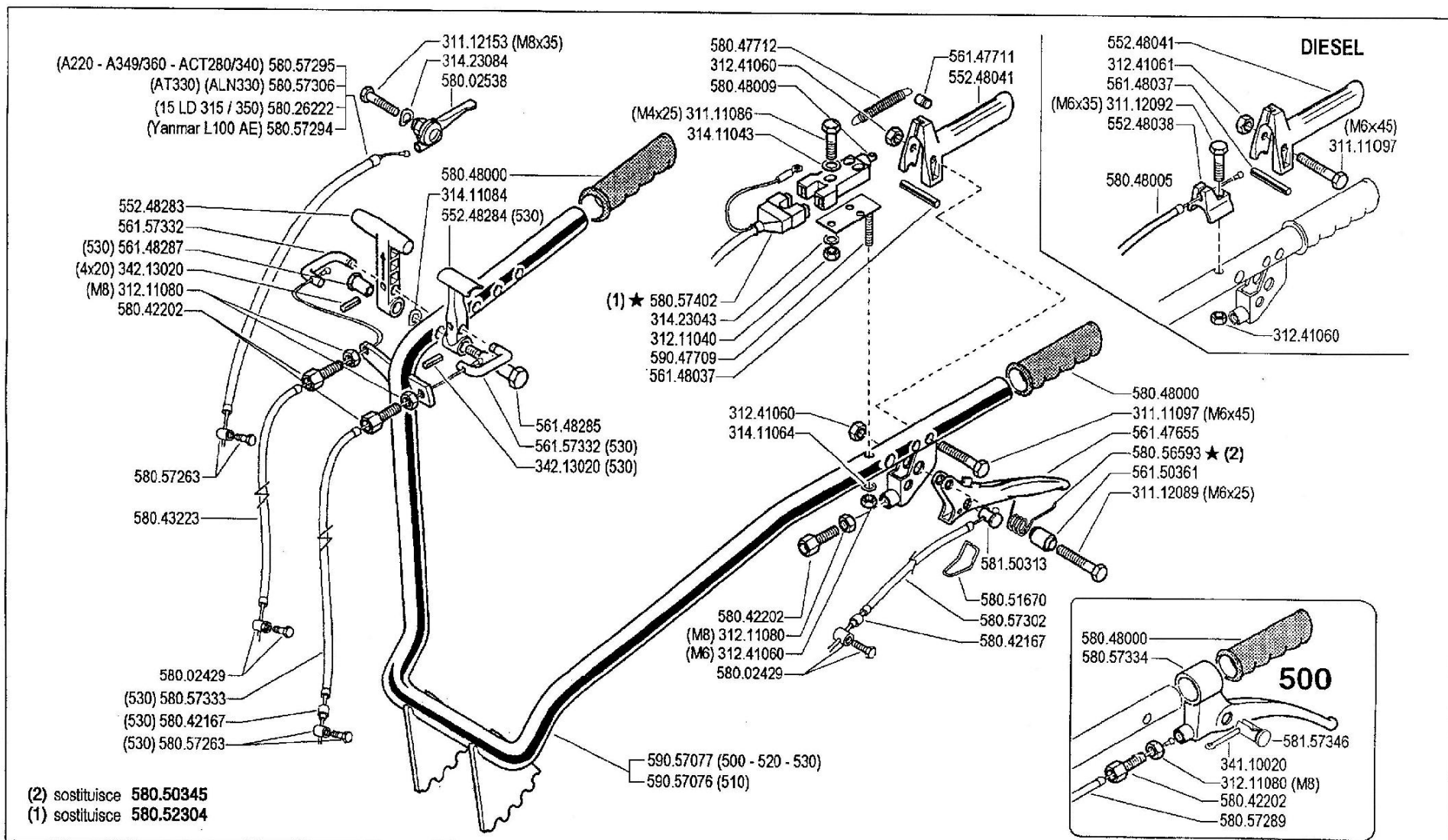

FERRARI

500 serie 95

MANUBRIO (500 - 510 - 520 - 530)

HANDLEBAR
 MANILLAR

MANCHERON
 LENKER

DALLA MACCHINA
 DE LA MAQUINA
 DE LA MACHINE
 FROM THE MACHINE
 AB DER MASCHINE

AGGIORNAMENTO

REVISION

MISE A JOUR

APLAZAMIENTO

ANPASSUNG

08

Rev.
4

11/2002

★N.

ZENNE

Pos.	Code	Q.ty	Description	Notes
31111086	31111086	0	SCREW TE M4X25 UNI 5739 8G	
31111097	31111097	0	SCREW TE M6X45 UNI 5737 8G	
31112089	31112089	0	SCREW TE M6X25 UNI 5739 8G	
31112092	31112092	0	SCREW TE M6X35 UNI 5739 8G	
31112153	31112153	0	SCREW TE M8X35 UNI 5739 8G	
31211040	31211040	0	NUT M4	
31211080	31211080	0	NUT M8	
31241060	31241060	0	HEXAGON SELFLOCK NUT M6	
31241061	31241061	0	SELFLOCK NUT M6 6S	
31411043	31411043	0	WASHER 4,3X9	
31411064	31411064	0	WASHER 6,4x12,5	
31411084	31411084	0	WASHER 8,4x17	
31423043	31423043	0	SPRING WASHER 4,3	
31423084	31423084	0	SPRING WASHER 8,4	
34110020	34110020	0	SPLIT PIN	
34213020	34213020	0	ROLL PIN	
55248038	55248038	0	STOP	
55248041	55248041	0	LEVER	
55248283	55248283	0	COMMAND LEVER	
55248284	55248284	0	LEVER	
56147655	56147655	0	CLUTCH LEVER	
56147711	56147711	0	PIN	
56148037	56148037	0	LEVER STOP	
56148285	56148285	0	PIN	
56148287	56148287	0	STUD BOLT	
56150361	56150361	0	SPACER	
56157332	56157332	0	U BOLT	
58002429	58002429	0	CLAMPING SCREW	
58002538	58002538	0	COMMAND LEVER	
58026222	58026222	0	LINE AND SHEATH	
58042167	58042167	0	SHEATH TERMINAL	
58042202	58042202	0	ADJUSTING SCREW	
58043223	58043223	0	LINE AND SHEATH	
58047712	58047712	0	SPRING	

SERIAL

008_04 - HANDLEBAR (500-510-520-530)

CODE REV

008_4_13416

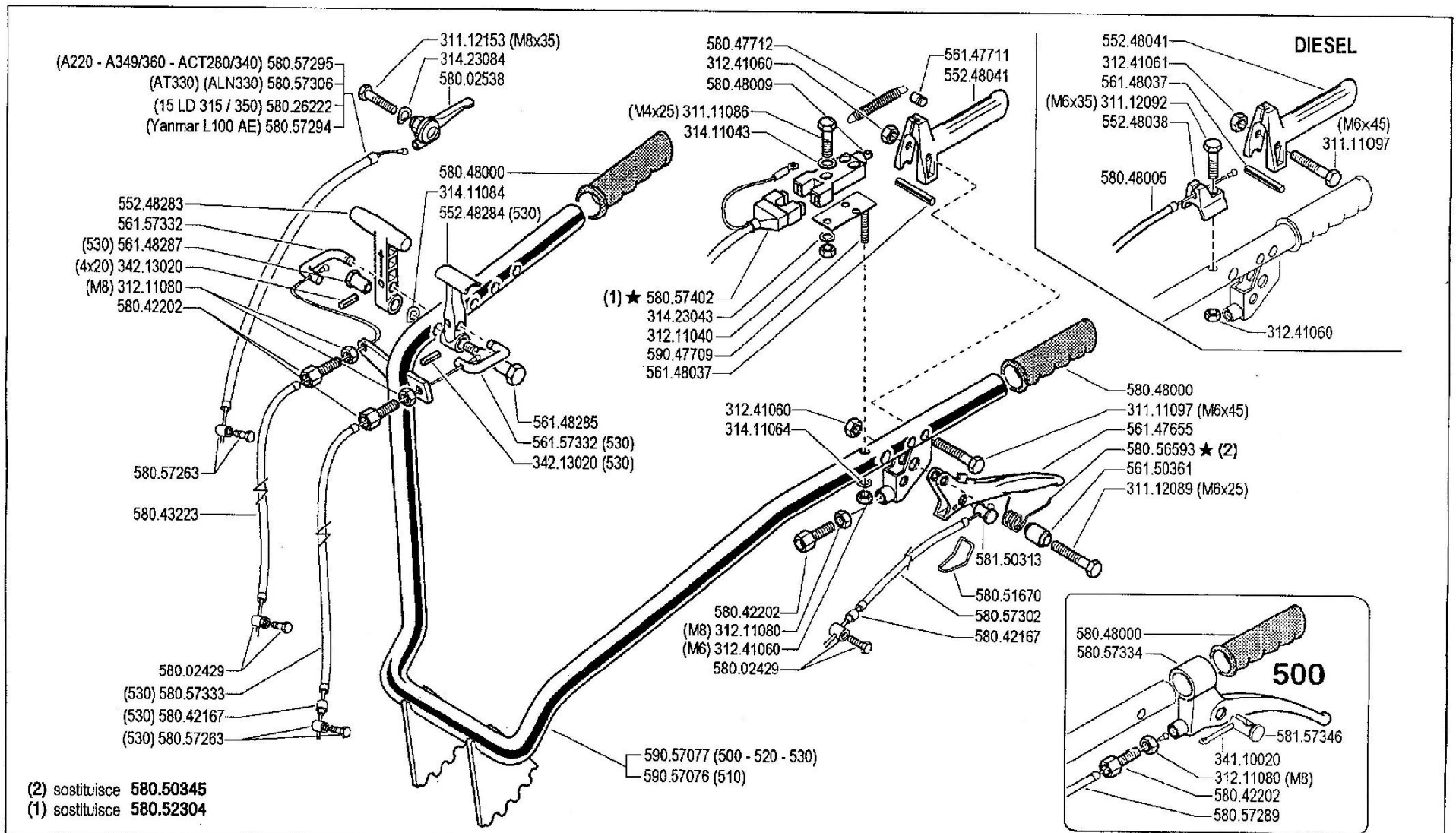

FERRARI

500 serie 95

MANUBRIO (500 - 510 - 520 - 530)

HANDLEBAR
 MANILLAR

MANCHERON
 LENKER

DALLA MACCHINA
 DE LA MAQUINA
 DE LA MACHINE
 FROM THE MACHINE
 AB DER MASCHINE

AGGIORNAMENTO

REVISION

MISE A JOUR

APLAZAMIENTO

ANPASSUNG

08

Rev.
4

11/2002

★N.

ZENNE

Pos.	Code	Q.ty	Description	Notes
58048000	58048000	0	KNOB	
58048005	58048005	0	LINE AND SHEATH	
58048009	58048009	0	SWITCH	
58051670	58051670	0	CLEVIS	
58056593	58056593	0	SPRING	
58057263	58057263	0	CLAMPING SCREW	
58057289	58057289	0	LINE AND SHEATH	
58057294	58057294	0	LINE AND SHEATH	
58057295	58057295	0	LINE AND SHEATH	
58057302	58057302	0	LINE AND SHEATH	
58057306	58057306	0	LINE AND SHEATH	
58057333	58057333	0	LINE AND SHEATH	
58057334	58057334	0	LEVER	
58057402	58057402	0	WIRING	
58150313	58150313	0	CABLE CLAMP	
58157346	58157346	0	CABLE CLAMP	
59047709	59047709	0	SWITCH SUPPORT	
59057076	59057076	0	COMPLETE HANDLE BAR	
59057077	59057077	0	COMPLETE HANDLE BAR	

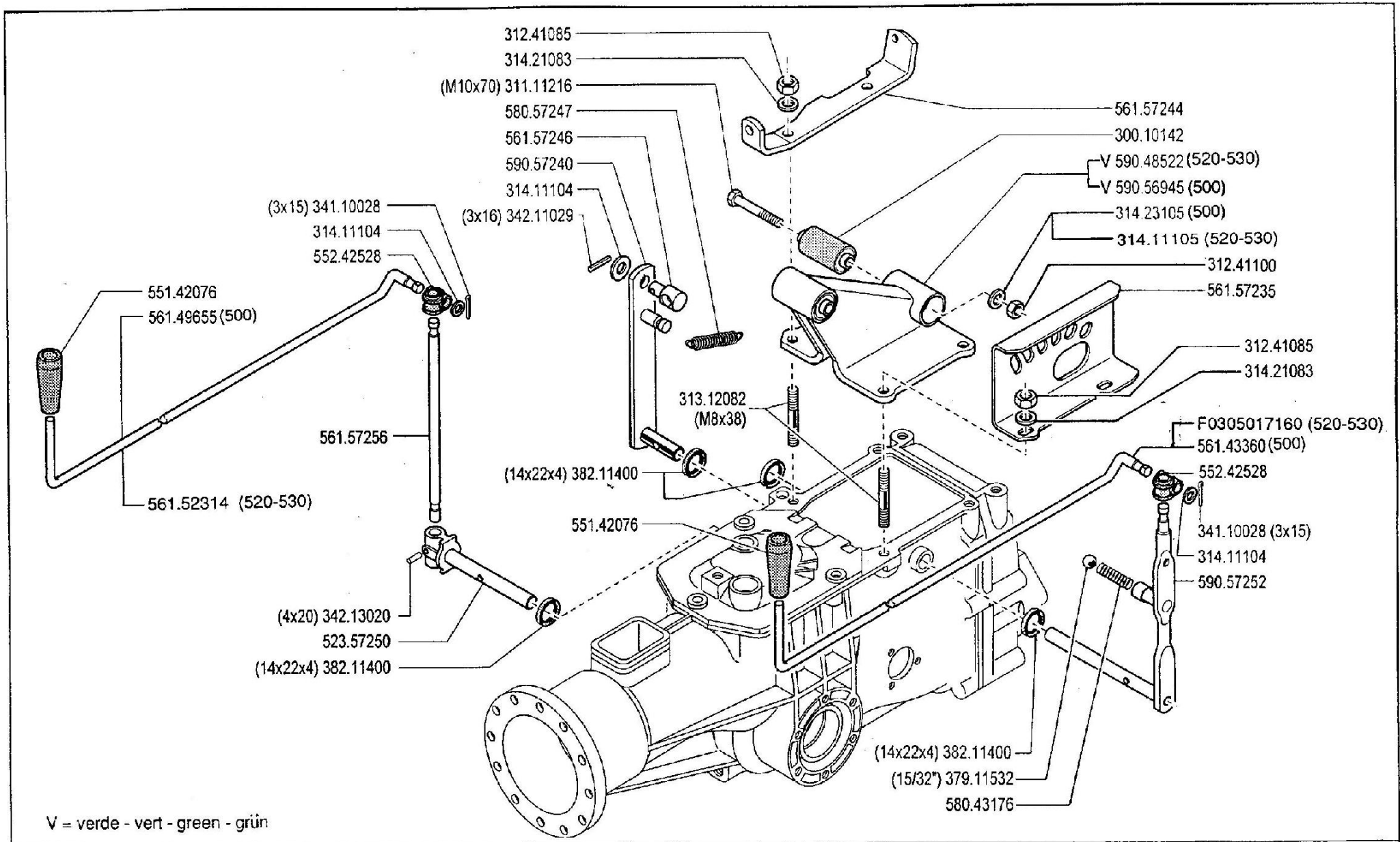

FERRARI

500 serie **95**

COMANDI

MANDOS
 COMMANDES

CONTROLS
 ANTRIEBE

DALLA MACCHINA
 DE LA MACQUINA
 DE LA MACHINE
 FROM THE MACHINE
 AB DER MASCHINE

N.

09.00

01.06.1995

Pos.	Code	Q.ty	Description	Notes
30010142	30010142	0	SILENT-BLOCK 10,2X30X45X49	
31111216	31111216	0	SCREW TE M10X70 UNI 5739 8G	
31241085	31241085	0	SELFLOCK NUT M8 6S	
31241100	31241100	0	SELFLOCK HEXAGON NUT M10	
31312082	31312082	0	STUD BOLT M8X38X14X20	
31411104	31411104	0	WASHER 10,5x18	
31411105	31411105	0	WASHER 10,5x21	
31421083	31421083	0	WASHER	
31423105	31423105	0	SPRING WASHER 10,5	
34110028	34110028	0	SPLIT PIN	
34211029	34211029	0	ROLL PIN	
34213020	34213020	0	ROLL PIN	
37911532	37911532	0	BALL 15/32	
38211400	38211400	0	OIL SEAL 14X22X4	
52357250	52357250	0	PIN	
55142076	55142076	0	KNOB	
55242528	55242528	0	JOINT	
56143360	56143360	0	PULL ROD	
56149655	56149655	0	PULL ROD	
56152314	56152314	0	ROD	
56157235	56157235	0	GEAR SELECTOR	
56157244	56157244	0	STOP	
56157246	56157246	0	STOP	
56157256	56157256	0	PTO LEVER	
58043176	58043176	0	SPRING	
58057247	58057247	0	SPRING	
59048522	59048522	0	SUPPORT	
59056945	59056945	0	SUPPORT	
59057240	59057240	0	LEVER	
59057252	59057252	0	GEAR LEVER	
F0305017	F0305017160	0	ROD	

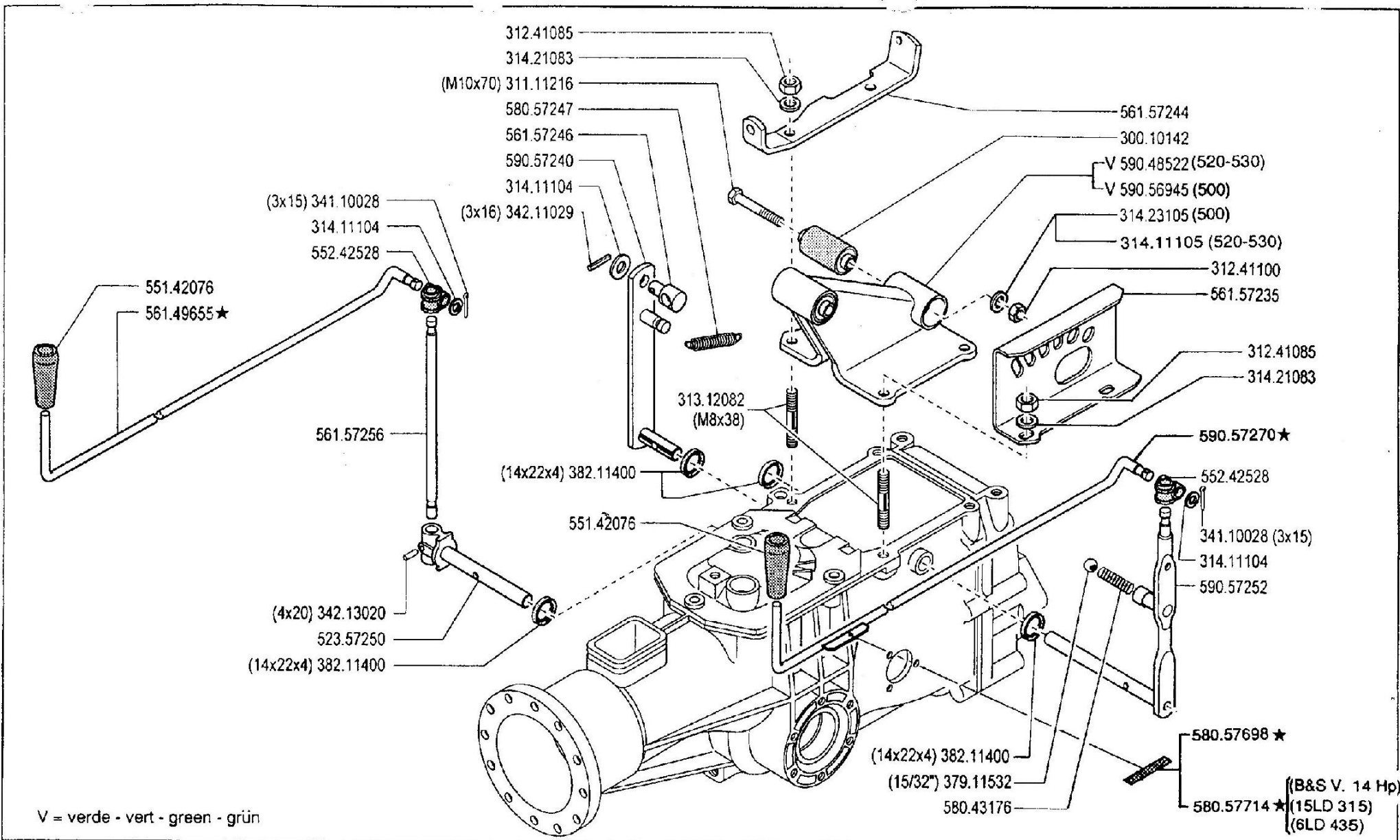

FERRARI	500 serie 95	COMANDI		DALLA MACCHINA		09.01
		MANDOS	CONTROLS	DE LA MAQUINA		
		COMMANDES	ANTRIEBE	DE LA MACHINE	21631 (530)	
				FROM THE MACHINE	155330 (520)	
				AB DER MASCHINE	★ N. AGGIORNAM. (500)	02.09.1996

Pos.	Code	Q.ty	Description	Notes
30010142	30010142	0	SILENT-BLOCK 10,2X30X45X49	
31111216	31111216	0	SCREW TE M10X70 UNI 5739 8G	
31241085	31241085	0	SELFLOCK NUT M8 6S	
31241100	31241100	0	SELFLOCK HEXAGON NUT M10	
31312082	31312082	0	STUD BOLT M8X38X14X20	
31411104	31411104	0	WASHER 10,5x18	
31411105	31411105	0	WASHER 10,5x21	
31421083	31421083	0	WASHER	
31423105	31423105	0	SPRING WASHER 10,5	
34110028	34110028	0	SPLIT PIN	
34211029	34211029	0	ROLL PIN	
34213020	34213020	0	ROLL PIN	
37911532	37911532	0	BALL 15/32	
38211400	38211400	0	OIL SEAL 14X22X4	
52357250	52357250	0	PIN	
55142076	55142076	0	KNOB	
55242528	55242528	0	JOINT	
56149655	56149655	0	PULL ROD	
56157235	56157235	0	GEAR SELECTOR	
56157244	56157244	0	STOP	
56157246	56157246	0	STOP	
56157256	56157256	0	PTO LEVER	
58043176	58043176	0	SPRING	
58057247	58057247	0	SPRING	
58057698	58057698	0	DECAL	
58057714	58057714	0	DECAL	
59048522	59048522	0	SUPPORT	
59056945	59056945	0	SUPPORT	
59057240	59057240	0	LEVER	
59057252	59057252	0	GEAR LEVER	
59057270	59057270	0	GEARSHIFT ROD	

SERIAL

009_01 - CONTROLS

Version: MF 500, MF 520, MF 530

CODE REV

009_1_13502

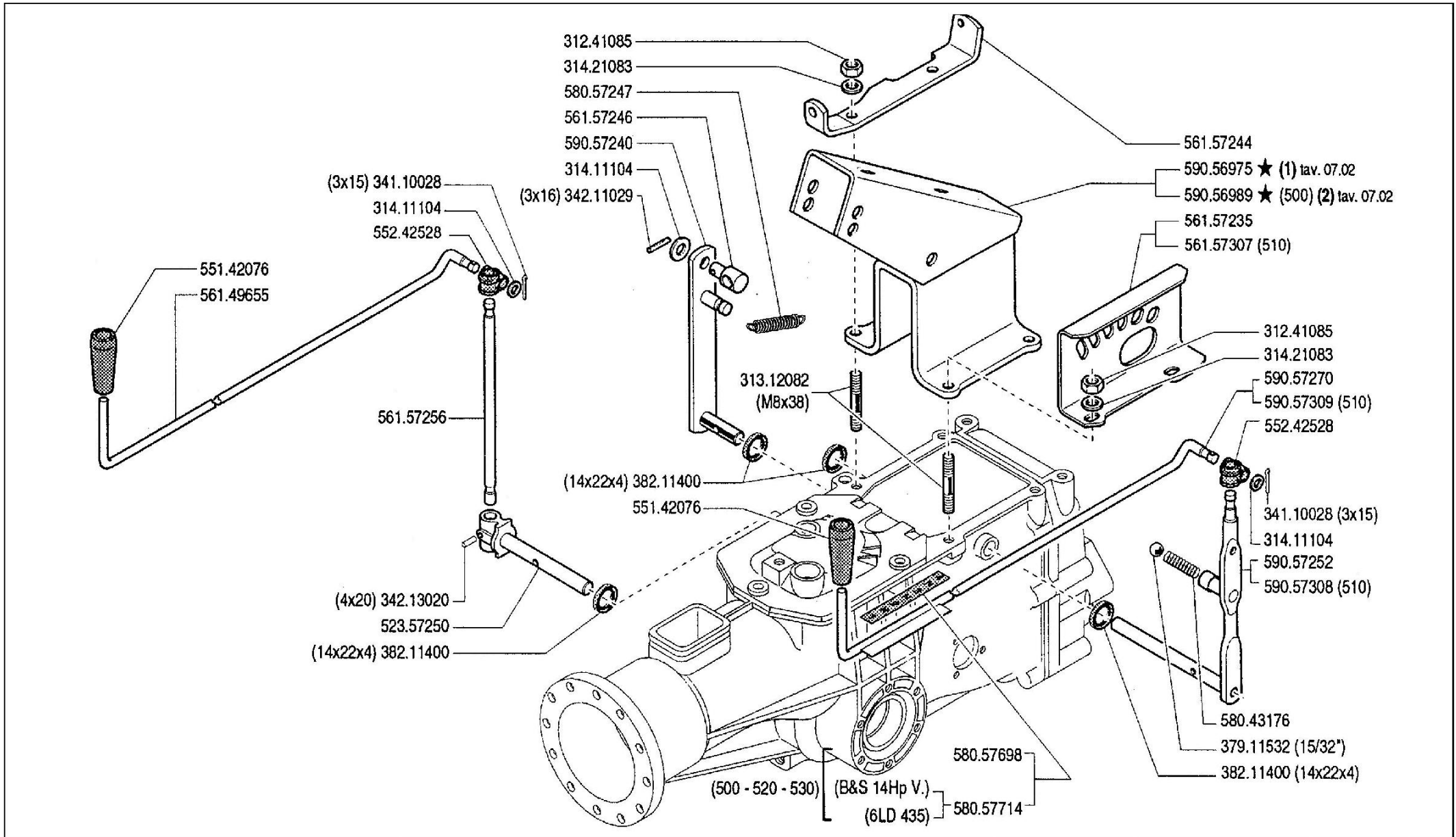

	500 serie 95	COMANDI (500-510-520-530)		DALLA MACCHINA DE LA MAQUINA DE LA MACHINE FROM THE MACHINE AB DER MASCHINE	22690 (530) 158833 (520) ★ (510) 80952 (500)	09	02	
		CONTROLS MANDOS	COMMANDES ANTRIEBE					★N.
		9/1997						

Pos.	Code	Q.ty	Description	Notes
31241085	31241085	0	SELFLOCK NUT M8 6S	
31312082	31312082	0	STUD BOLT M8X38X14X20	
31411104	31411104	0	WASHER 10,5x18	
31421083	31421083	0	WASHER	
34110028	34110028	0	SPLIT PIN	
34211029	34211029	0	ROLL PIN	
34213020	34213020	0	ROLL PIN	
37911532	37911532	0	BALL 15/32	
38211400	38211400	0	OIL SEAL 14X22X4	
52357250	52357250	0	PIN	
55142076	55142076	0	KNOB	
55242528	55242528	0	JOINT	
56149655	56149655	0	PULL ROD	
56157235	56157235	0	GEAR SELECTOR	
56157244	56157244	0	STOP	
56157246	56157246	0	STOP	
56157256	56157256	0	PTO LEVER	
56157307	56157307	0	SELECTOR	
58043176	58043176	0	SPRING	
58057247	58057247	0	SPRING	
58057698	58057698	0	DECAL	
58057714	58057714	0	DECAL	
59056975	59056975	0	SUPPORT	
59056989	59056989	0	SUPPORT	
59057240	59057240	0	LEVER	
59057252	59057252	0	GEAR LEVER	
59057270	59057270	0	GEARSHIFT ROD	
59057308	59057308	0	GEAR LEVER	
59057309	59057309	0	GEARSHIFT ROD	

SERIAL

009_02 - CONTROLS (500-510-520-530)

Version: MF 510, MF 530, MF 520, MF 500

CODE REV

009_2_13534

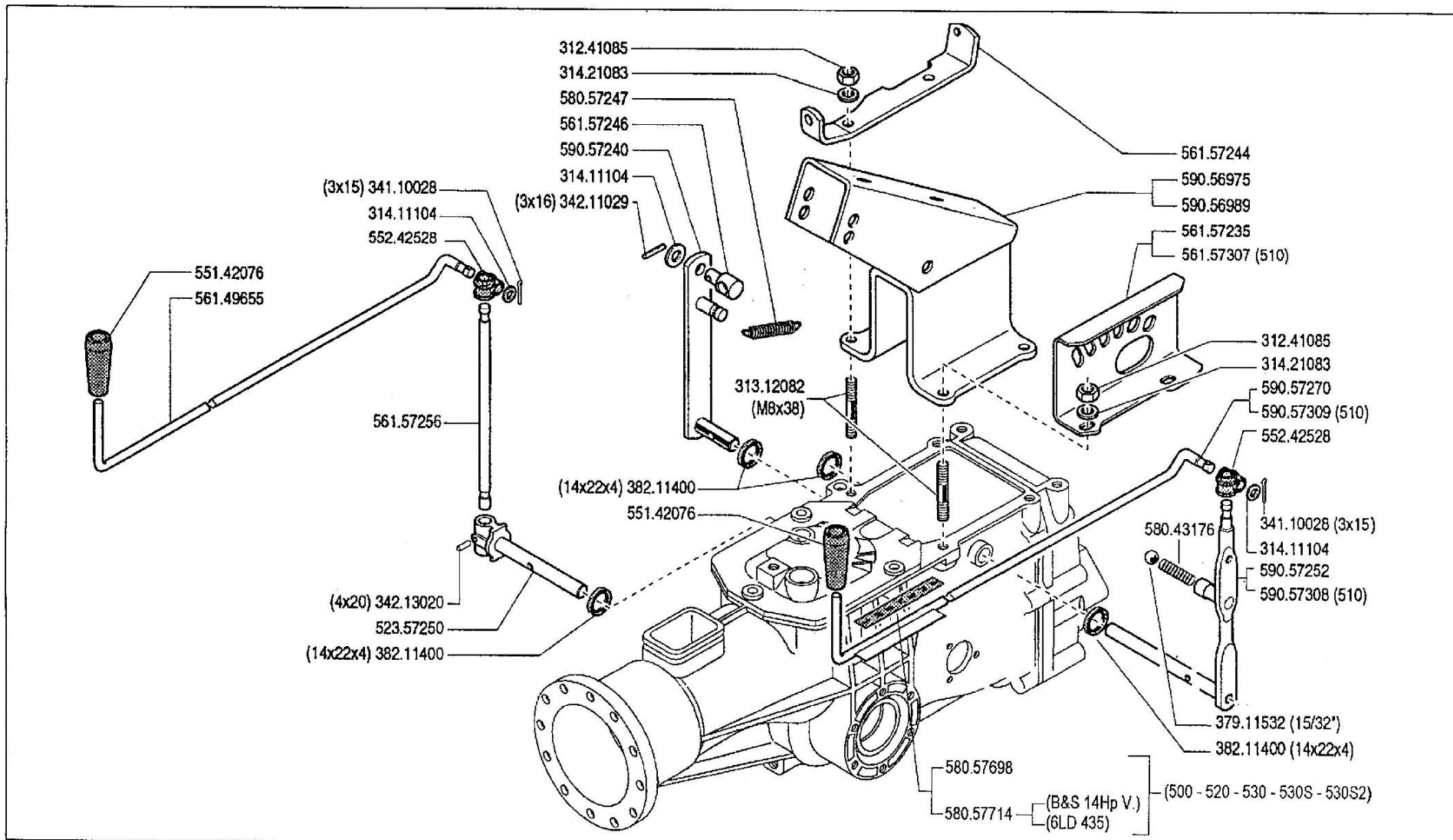

FERRARI

500 serie **95**

COMANDI (500 - 510 - 520 - 530 - 530S★ - 530S2★)

CONTROLS
MANDOS

COMMANDES
ANTRIEBE

DALLA MACCHINA
DE LA MAQUINA
FROM THE MACHINE
AB DER MASCHINE

AGGIORNAMENTO
REVISION
MISE A JOUR
APLAZAMIENTO
ANPASSUNG

09

Rev.
3

★N

10/2001

ZENNE

Pos.	Code	Q.ty	Description	Notes
31241085	31241085	0	SELFLOCK NUT M8 6S	
31312082	31312082	0	STUD BOLT M8X38X14X20	
31411104	31411104	0	WASHER 10,5x18	
31421083	31421083	0	WASHER	
34110028	34110028	0	SPLIT PIN	
34211029	34211029	0	ROLL PIN	
34213020	34213020	0	ROLL PIN	
37911532	37911532	0	BALL 15/32	
38211400	38211400	0	OIL SEAL 14X22X4	
52357250	52357250	0	PIN	
55142076	55142076	0	KNOB	
55242528	55242528	0	JOINT	
56149655	56149655	0	PULL ROD	
56157235	56157235	0	GEAR SELECTOR	
56157244	56157244	0	STOP	
56157246	56157246	0	STOP	
56157256	56157256	0	PTO LEVER	
56157307	56157307	0	SELECTOR	
58043176	58043176	0	SPRING	
58057247	58057247	0	SPRING	
58057698	58057698	0	DECAL	
58057714	58057714	0	DECAL	
59056975	59056975	0	SUPPORT	
59056989	59056989	0	SUPPORT	
59057240	59057240	0	LEVER	
59057252	59057252	0	GEAR LEVER	
59057270	59057270	0	GEARSHIFT ROD	
59057308	59057308	0	GEAR LEVER	
59057309	59057309	0	GEARSHIFT ROD	

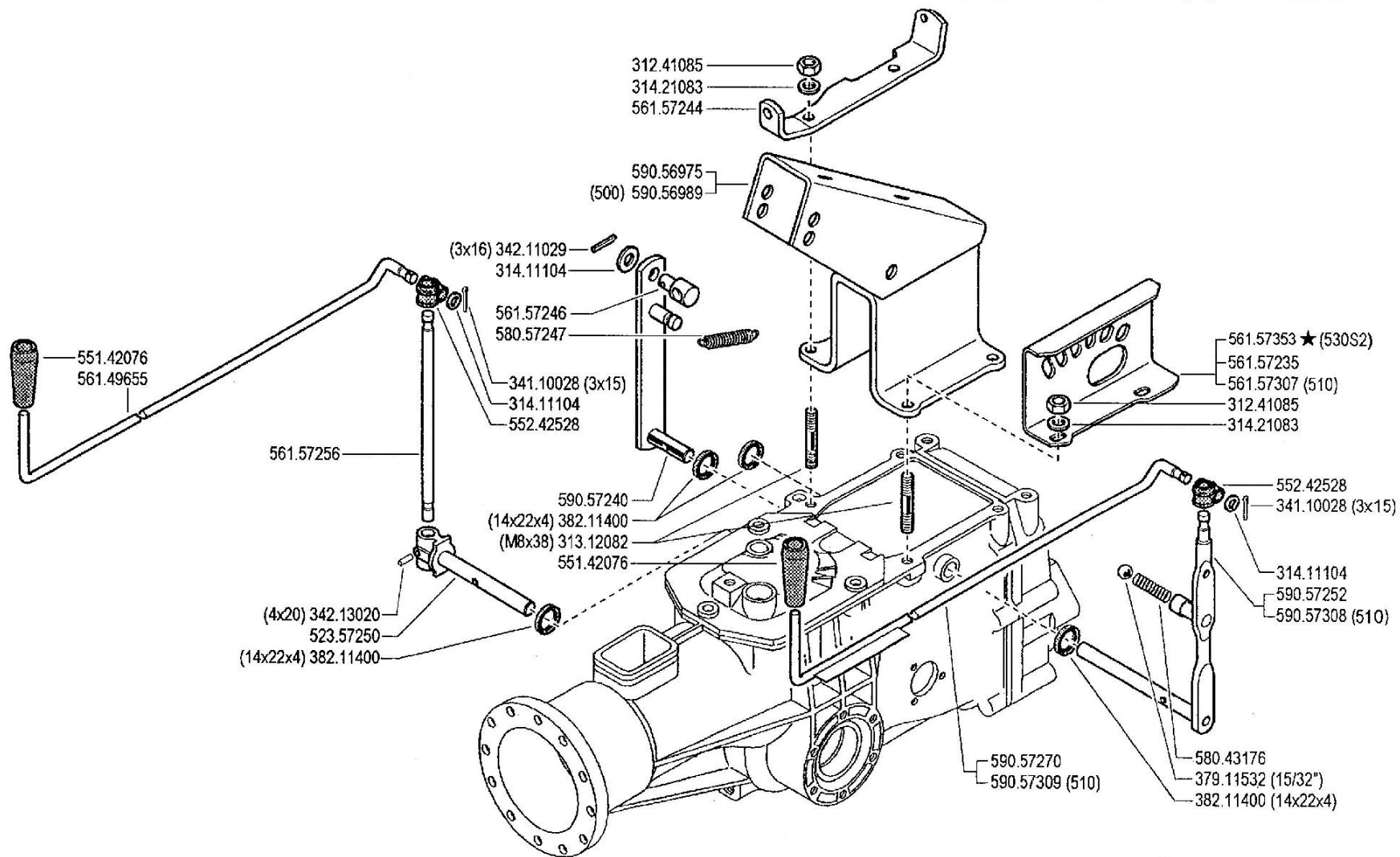

FERRARI

500 serie **95**

COMANDI (500 - 510 - 520 - 530 - 530S2)

CONTROLS
MANDOS

COMMANDES
ANTRIEBE

★ DALLA MACCHINA
DE LA MAQUINA
DE LA MACHINE
FROM THE MACHINE
AB DER MASCHINE

ALLA MACCHINA
A LA MAQUINA
A LA MACHINE
TO THE MACHINE
BIS MASCHINE

09

Rev.
4

N. 721207
721255

721222

1/2004

ZEMME

Pos.	Code	Q.ty	Description	Notes
31241085	31241085	0	SELFLOCK NUT M8 6S	
31312082	31312082	0	STUD BOLT M8X38X14X20	
31411104	31411104	0	WASHER 10,5x18	
31421083	31421083	0	WASHER	
34110028	34110028	0	SPLIT PIN	
34211029	34211029	0	ROLL PIN	
34213020	34213020	0	ROLL PIN	
37911532	37911532	0	BALL 15/32	
38211400	38211400	0	OIL SEAL 14X22X4	
52357250	52357250	0	PIN	
55142076	55142076	0	KNOB	
55242528	55242528	0	JOINT	
56149655	56149655	0	PULL ROD	
56157235	56157235	0	GEAR SELECTOR	
56157244	56157244	0	STOP	
56157246	56157246	0	STOP	
56157256	56157256	0	PTO LEVER	
56157307	56157307	0	SELECTOR	
56157353	56157353	0	GEAR SELECTOR	
58043176	58043176	0	SPRING	
58057247	58057247	0	SPRING	
59056975	59056975	0	SUPPORT	
59056989	59056989	0	SUPPORT	
59057240	59057240	0	LEVER	
59057252	59057252	0	GEAR LEVER	
59057270	59057270	0	GEARSHIFT ROD	
59057308	59057308	0	GEAR LEVER	
59057309	59057309	0	GEARSHIFT ROD	

SERIAL

009_04 - CONTROLS(500/10/20-530-530S2)

CODE REV

009_4_13594

V 561.48218
 580.48214
 580.48215
 V 590.48200

(M8x25) 311.52085
 V 590.48208

311.12092 (M6x35)
 590.48469
 314.22064
 312.41060
 580.50345
 561.48470
 561.50361
 311.12089 (M6x25)
 312.41060
 (M8) 312.11080
 580.42202
 580.52302
 581.50313
 580.47649

V 590.48200
 580.42200
 311.12090 (M6x16)
 580.48215

V 590.48208
 (M8x25) 311.52085
 580.48214
 V 561.48218

V = verde - vert - green - grün

FERRARI

500 serie **95**

FRENI

FRENOS
 FREINS

BRAKES
 BREMSEN

DALLA MACCHINA
 DE LA MAQUINA
 DE LA MACHINE
 FROM THE MACHINE
 AB DER MASCHINE

N.

10.00

01.06.1995

Pos.	Code	Q.ty	Description	Notes
31112089	31112089	0	SCREW TE M6X25 UNI 5739 8G	
31112090	31112090	0	SCREW TE M6X16 UNI 5739 8G	
31112092	31112092	0	SCREW TE M6X35 UNI 5739 8G	
31152085	31152085	0	SCREW TCEI M8X25 UNI 5931	
31211080	31211080	0	NUT M8	
31241060	31241060	0	HEXAGON SELFLOCK NUT M6	
31422064	31422064	0	SPRING WASHER 6,4	
56148218	56148218	0	BRAKE DRUM	
56148470	56148470	0	LEVER	
56150361	56150361	0	SPACER	
58042200	58042200	0	CLAMPING SCREW	
58042202	58042202	0	ADJUSTING SCREW	
58047649	58047649	0	CLEVIS	
58048214	58048214	0	BRAKE BLOCK	
58048215	58048215	0	SPRING	
58050345	58050345	0	SPRING	
58052302	58052302	0	LINE AND SHEATH	
58150313	58150313	0	CABLE CLAMP	
59048200	59048200	0	HALF DISC	
59048208	59048208	0	HALF DISC	
59048469	59048469	0	CONNECTION	

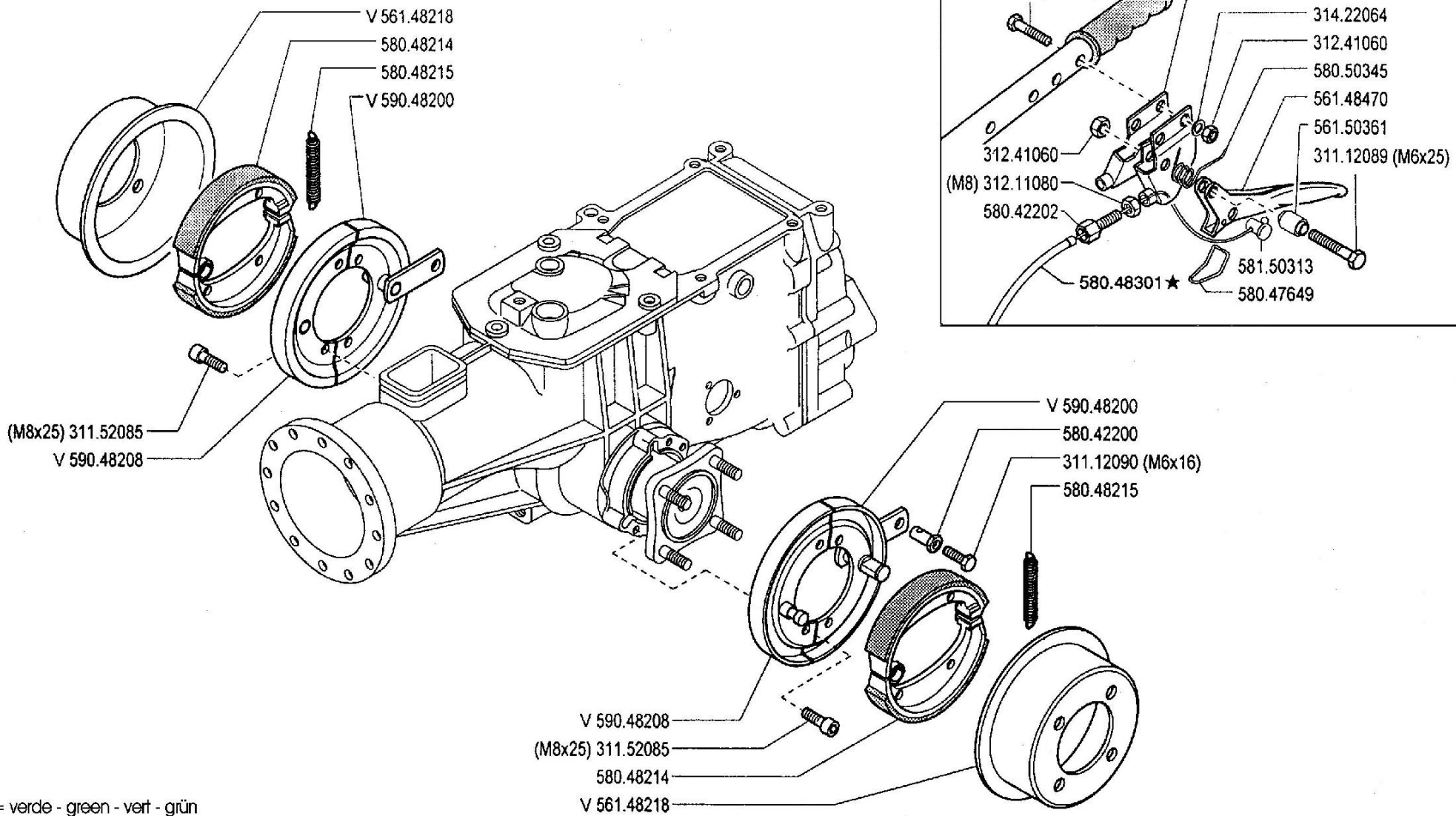

V = verde - green - vert - grün

FERRARI

500 serie 95

FRENI (530)

BRAKES
FRENOS

FREINS
BREMSEN

DALLA MACCHINA
DE LA MAQUINA
DE LA MACHINE
FROM THE MACHINE
AB DER MASCHINE

★N.

21631

10

01

9/1996

ZENITE

Pos.	Code	Q.ty	Description	Notes
31112089	31112089	0	SCREW TE M6X25 UNI 5739 8G	
31112090	31112090	0	SCREW TE M6X16 UNI 5739 8G	
31112092	31112092	0	SCREW TE M6X35 UNI 5739 8G	
31152085	31152085	0	SCREW TCEI M8X25 UNI 5931	
31211080	31211080	0	NUT M8	
31241060	31241060	0	HEXAGON SELFLOCK NUT M6	
31422064	31422064	0	SPRING WASHER 6,4	
56148218	56148218	0	BRAKE DRUM	
56148470	56148470	0	LEVER	
56150361	56150361	0	SPACER	
58042200	58042200	0	CLAMPING SCREW	
58042202	58042202	0	ADJUSTING SCREW	
58047649	58047649	0	CLEVIS	
58048214	58048214	0	BRAKE BLOCK	
58048215	58048215	0	SPRING	
58048301	58048301	0	LINE AND SHEATH	
58050345	58050345	0	SPRING	
58150313	58150313	0	CABLE CLAMP	
59048200	59048200	0	HALF DISC	
59048208	59048208	0	HALF DISC	
59048469	59048469	0	CONNECTION	

	A	B	C
3.50 - 8" (500)	391.13502	394.13502	580.52325
3.50 - 8"	391.13502	394.13502	580.52326
4.00 - 8"	391.14008	394.14008	580.52326
4.0 - 10"	391.14010	394.14010	580.52327
5.0 - 10"	391.15010	394.15010	580.52327
21 x 11.00 - 8"	391.13501	TUBELESS	580.52274 ★ (1)

★ 924.57794

KIT GEMELLAGGIO PER 4.0-10" / 5.0-10"
 TWINNING KIT FOR 4.0-10" / 5.0-10"
 JUMELAGE KIT POUR 4.0-10" / 5.0-10"
 KIT GEMELOS POR 4.0-10" / 5.0-10"
 ZWILLINGSKIT 4.0-10" / 5.0-10"

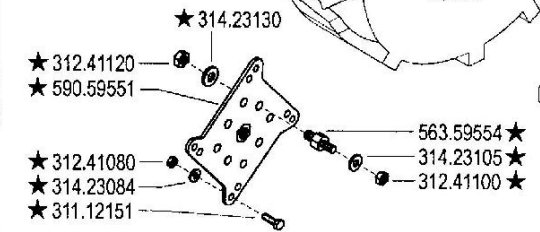
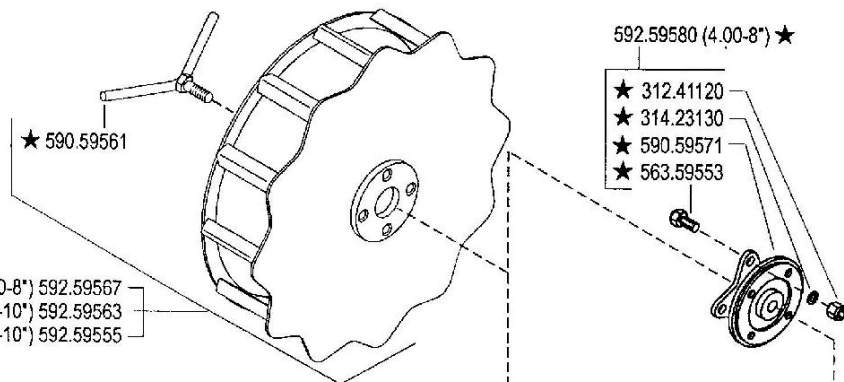
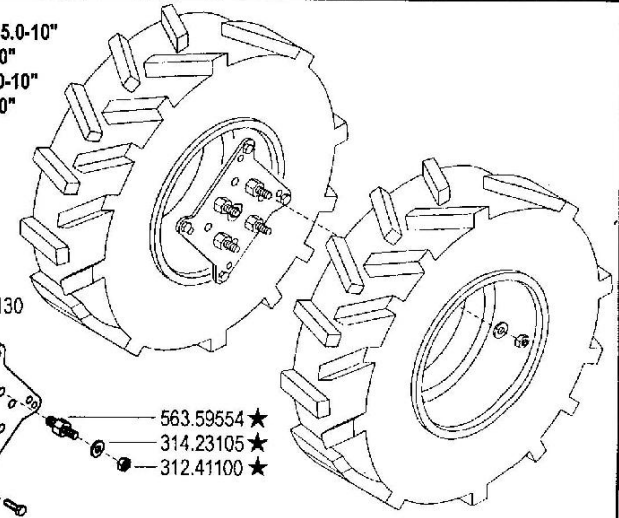

- ★ (4.00-8") 592.59567
- ★ (4.0-10") 592.59563
- ★ (5.0-10") 592.59555

- (4.0-10")
- (5.0-10")
- (21x11.00-8")

- ★ 592.59578
- ★ 563.59553
- ★ 311.12219
- ★ 314.21101
- ★ 311.12151
- ★ 314.23084
- ★ 312.41080
- ★ 314.23084
- ★ 590.59551
- ★ 312.41120
- ★ 314.23130

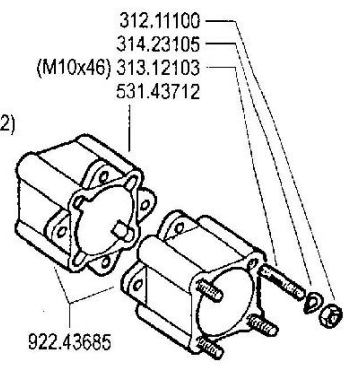
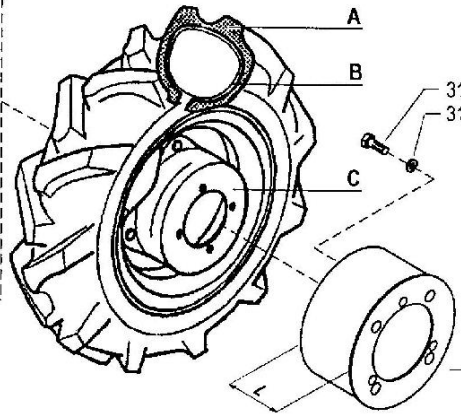

- 590.47745 (L=66)
- 590.47743 (L=126)

(1) sostituisce 580.52331

FERRARI

500 serie 95

RUOTE

WHEELS
RUEDAS

ROUES
RÄDER

DALLA MACCHINA
DE LA MAQUINA
DE LA MACHINE
FROM THE MACHINE
AB DER MASCHINE

AGGIORNAMENTO
REVISION
MISE A JOUR
APLAZAMIENTO
ANPASSUNG

11
3
12/2003

★N

ZENNE

Pos.	Code	Q.ty	Description	Notes
31112149	31112149	0	SCREW TE M8X12 UNI 5739 8G	
31112151	31112151	0	SCREW TE M8X25 UNI 5739 8G	
31112219	31112219	0	SCREW TE M10X25 UNI 5739	
31211100	31211100	0	NUT M10	
31241080	31241080	0	HEXAGON SELFLOCK NUT M8	
31241100	31241100	0	SELFLOCK HEXAGON NUT M10	
31241120	31241120	0	SELFLOCK NUT M12	
31312103	31312103	0	STUD BOLT M10X46X24X16	
31421101	31421101	0	WASHER	
31423084	31423084	0	SPRING WASHER 8,4	
31423105	31423105	0	SPRING WASHER 10,5	
31423130	31423130	0	SPRING WASHER 13	
39113501	39113501	0	TYRE 21X11.00-8	
39113502	39113502	0	TYRE 3.50-8 2PR	
39114008	39114008	0	TYRE 4.00-8 2PR	
39114010	39114010	0	TYRE 4.0-10 2PR	
39115010	39115010	0	TYRE 5.00-10 2PR	
39413502	39413502	0	INNER TUBE	
39414008	39414008	0	INNER TUBE	
39414010	39414010	0	INNER TUBE	
39415010	39415010	0	INNER TUBE	
53143712	53143712	0	SPACER	
56359553	56359553	0	PIN	
56359554	56359554	0	PIN	
58052274	58052274	0	RIM	
58052325	58052325	0	RIM	
58052326	58052326	0	RIM	
58052327	58052327	0	RIM	
59047743	59047743	0	HUBCOVER	
59047745	59047745	0	HUBCOVER	
59059551	59059551	0	FLANGE	
59059561	59059561	0	SCREW	
59059571	59059571	0	FLANGE	
59259555	59259555	0	SUPER-BITE WHEEL X 5.00-10	

SERIAL

W011_03 - HEELS

CODE REV

011_3_13744

	A	B	C
3.50 - 8" (500)	391.13502	394.13502	580.52325
3.50 - 8"	391.13502	394.13502	580.52326
4.00 - 8"	391.14008	394.14008	580.52326
4.0 - 10"	391.14010	394.14010	580.52327
5.0 - 10"	391.15010	394.15010	580.52327
21 x 11.00 - 8"	391.13501	TUBELESS	580.52274 ★ (1)

★ 924.57794

KIT GEMELLAGGIO PER 4.0-10" / 5.0-10"
 TWINNING KIT FOR 4.0-10" / 5.0-10"
 JUMELAGE KIT POUR 4.0-10" / 5.0-10"
 KIT GEMELOS POR 4.0-10" / 5.0-10"
 ZWILLINGSKIT 4.0-10" / 5.0-10"

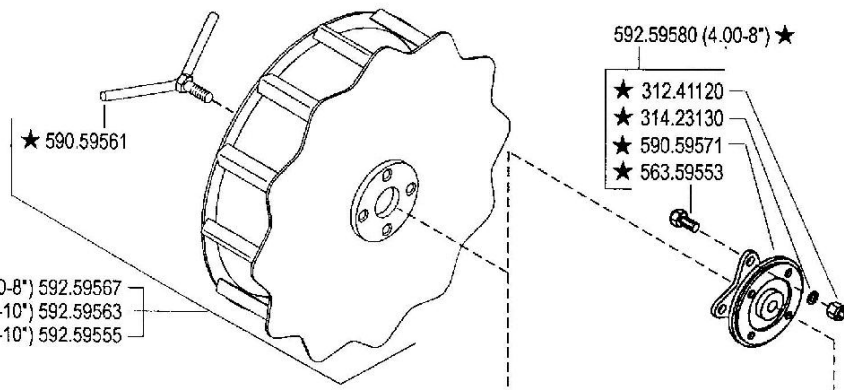
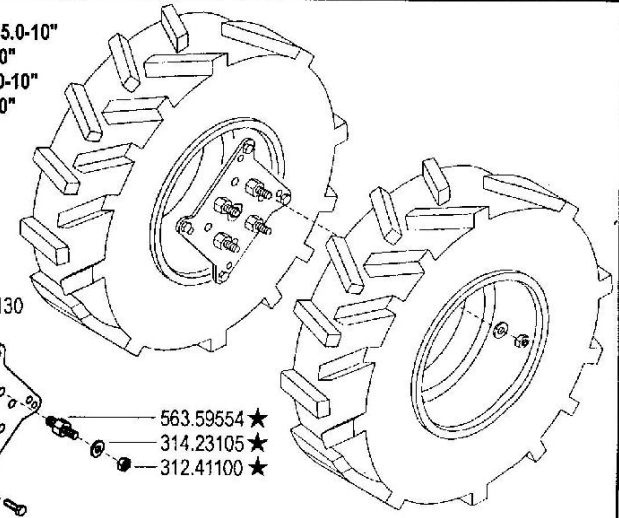

- ★ (4.00-8") 592.59567
- ★ (4.0-10") 592.59563
- ★ (5.0-10") 592.59555

- (4.0-10")
- (5.0-10")
- (21x11.00-8")

- ★ 592.59578
- ★ 563.59553
- ★ 311.12219
- ★ 314.21101
- ★ 311.12151
- ★ 314.23084
- ★ 312.41080
- ★ 314.23084
- ★ 590.59551
- ★ 312.41120
- ★ 314.23130

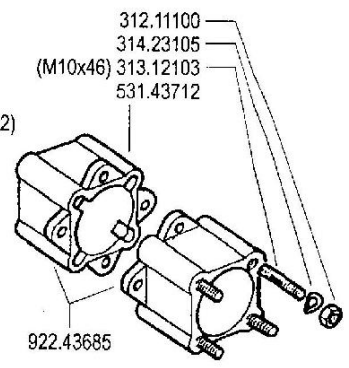
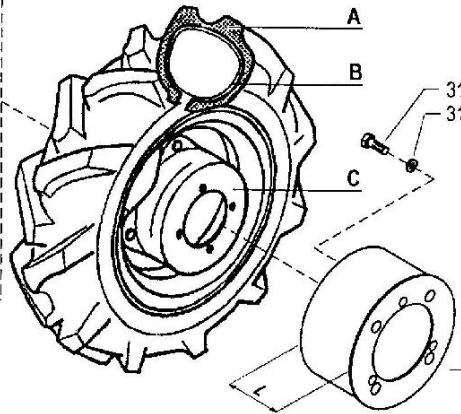

- 590.47745 (L=66)
- 590.47743 (L=126)

(1) sostituisce 580.52331

FERRARI

500 serie 95

RUOTE

WHEELS
RUEDAS

ROUES
RÄDER

DALLA MACCHINA
DE LA MAQUINA
DE LA MACHINE
FROM THE MACHINE
AB DER MASCHINE

AGGIORNAMENTO
REVISION
MISE A JOUR
APLAZAMIENTO
ANPASSUNG

11
3
12/2003

★ N

ZENNE

Pos.	Code	Q.ty	Description	Notes
59259563	59259563	0	WHEEL	
59259567	59259567	0	WHEEL	
59259578	59259578	0	FLANGE KIT	
59259580	59259580	0	FLANGE KIT	
92243685	92243685	0	PAIR WHEEL SPACERS 6 CM	
92457794	92457794	0	ADAPTOR PLATES 10 WHEELS (PAIR)	

500

580.52018

FERRARI

580.52019

FERRARI

580.52020

520

580.52021

520

580.52022

530

580.52023

530

580.52024

510

580.52033

510

580.52034



580.46901



580.46912

**FRIZIONE
EMBRAYAGE
EMBRAGUE**

580.46903



580.57698



580.57678



580.46913

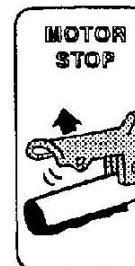

580.46902



580.46909



580.46910



580.57722

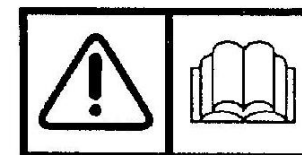

580.57724

FERRARI

500 serie 95

ADHESIVOS
AUTOCOLLANTS

ADESIVI

STICKERS
AUFKLEBES

DALLA MACCHINA
DE LA MAQUINA
DE LA MACHINE
FROM THE MACHINE
AB DER MASCHINE

N.

12.00

9/1997

Pos.	Code	Q.ty	Description	Notes
58046901	58046901	0	DECAL	
58046902	58046902	0	DECAL	
58046903	58046903	0	DECAL	
58046909	58046909	0	DECAL	
58046910	58046910	0	DECAL	
58046912	58046912	0	DECAL	
58046913	58046913	0	DECAL	
58052018	58052018	0	DECAL	
58052019	58052019	0	DECAL	
58052020	58052020	0	DECAL	
58052021	58052021	0	DECAL	
58052022	58052022	0	DECAL	
58052023	58052023	0	DECAL	
58052024	58052024	0	DECAL	
58052033	58052033	0	DECAL	
58052034	58052034	0	DECAL	
58057678	58057678	0	DECAL	
58057698	58057698	0	DECAL	
58057712	58057712	0	DECAL	
58057722	58057722	0	DECAL	
58057724	58057724	0	DECAL	

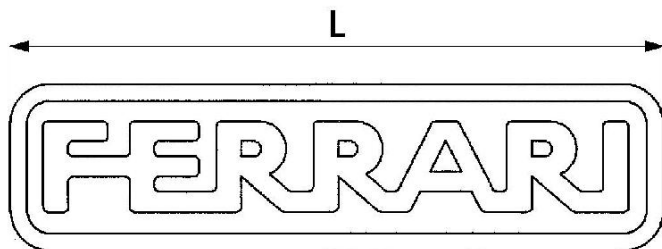

580.52019 (L= 87)
 580.52029 (L= 140) ★
 580.52020 (L= 174)

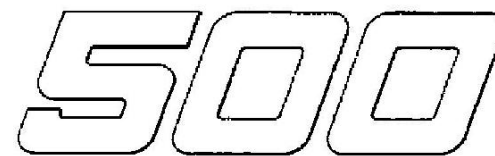

580.52018



580.52033



580.52021

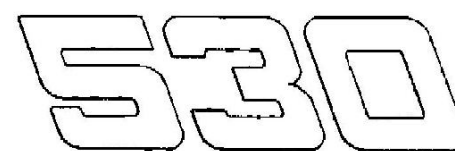

580.52023



580.52034



580.52022



580.52024



580.52144 ★



580.52146 ★



580.52148 ★



580.52145 ★



580.52147 ★



580.52149 ★

FERRARI

500 serie **95**

ADESIVI

STICKERS
 ADHESIVOS

AUTOCOLLANTS
 AUFKLEBES

DALLA MACCHINA
 DE LA MAQUINA
 DE LA MACHINE
 FROM THE MACHINE
 AB DER MASCHINE

AGGIORNAMENTO

REVISION

MISE A JOUR

APLAZAMIENTO

ANPASSUNG

12

Mod.
01

1/2000

★N.

Pos.	Code	Q.ty	Description	Notes
58052018	58052018	0	DECAL	
58052019	58052019	0	DECAL	
58052020	58052020	0	DECAL	
58052021	58052021	0	DECAL	
58052022	58052022	0	DECAL	
58052023	58052023	0	DECAL	
58052024	58052024	0	DECAL	
58052029	58052029	0	DECAL	
58052033	58052033	0	DECAL	
58052034	58052034	0	DECAL	
58052144	58052144	0	DECAL	
58052145	58052145	0	DECAL	
58052146	58052146	0	DECAL	
58052147	58052147	0	DECAL	
58052148	58052148	0	DECAL	
58052149	58052149	0	DECAL	

510

580.52033

510

580.52034

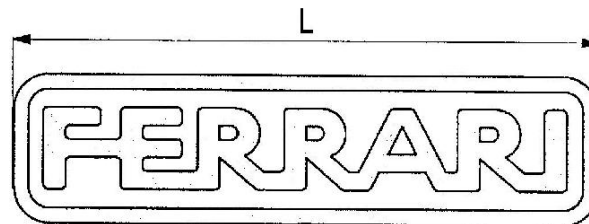

580.52019 (L= 87)
580.52029 (L= 140)
580.52020 (L= 174)

515

580.52144

515

580.52145

520

580.52021

520

580.52022

500

580.52018

530

580.52023

530

580.52024

515 L

580.52146

530 S

580.52150 ★

530 S

580.52151 ★

515 L

580.52147

530 S2

580.52154 ★

530 S2

580.52155 ★

515 S

580.52148

515 S

580.52149

FERRARI

500 serie 95

ADERIVI

STICKERS
ADHESIVOS

AUTOCOLLANTS
AUFKLEBES

DALLA MACCHINA
DE LA MAQUINA
DE LA MACHINE
FROM THE MACHINE
AB DER MASCHINE

AGGIORNAMENTO

REVISION

MISE A JOUR

APLAZAMIENTO

ANPASSUNG

12

Rev.
2

10/2001

★N

ZENIE

Pos.	Code	Q.ty	Description	Notes
58052018	58052018	0	DECAL	
58052019	58052019	0	DECAL	
58052020	58052020	0	DECAL	
58052021	58052021	0	DECAL	
58052022	58052022	0	DECAL	
58052023	58052023	0	DECAL	
58052024	58052024	0	DECAL	
58052029	58052029	0	DECAL	
58052033	58052033	0	DECAL	
58052034	58052034	0	DECAL	
58052144	58052144	0	DECAL	
58052145	58052145	0	DECAL	
58052146	58052146	0	DECAL	
58052147	58052147	0	DECAL	
58052148	58052148	0	DECAL	
58052149	58052149	0	DECAL	
58052150	58052150	0	DECAL	
58052151	58052151	0	DECAL	
58052154	58052154	0	DECAL	
58052155	58052155	0	DECAL	

4

N

3

N

2

N

1

580.57698

PERICOLO DI RIBALZAMENTO
DANGER DE CAPOTAGE
DANGER OF UPSETTING
UEBERSCHLAGENSFAHR
PELIGRO DE VUELCO

580.57722

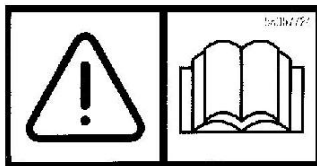

580.57724

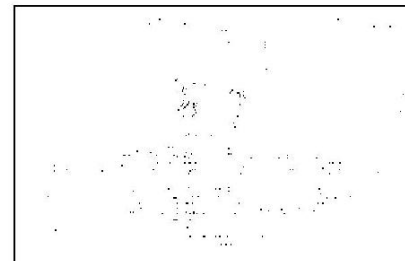

580.46909

N



580.57712

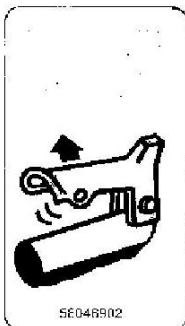

580.46902

**ATTENZIONE - ATTENTION
ATENCIÓN**

LA ZONA DEL TUBO DI SCARICO PUO' SUPERARE 65 °C
LA ZONE DU TUBAU D'ECHAPPEMENT PEUT DEPASSE 65 °C
LA ZONA DEL TUBO DE ESCAPE PUEDE SUPERAR LOS 65 °C

580.46910

580.57698



580.57678



N



580.57676 ★



580.46901

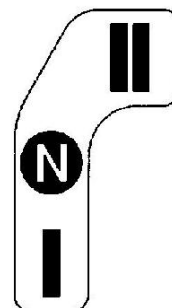

580.57732 ★

**FRIZIONE
EMBRAYAGE
EMBRAGUE**

580.46903

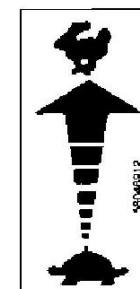

580.46912



580.46913

FERRARI

500 serie 95

ADESIVI

STICKERS
ADHESIVOS

AUTOCOLLANTS
AUFKLEBES

DALLA MACCHINA
DE LA MAQUINA
DE LA MACHINE
FROM THE MACHINE
AB DER MASCHINE

★ N.

13 00

1/2000

Mod.

ZENNE

Pos.	Code	Q.ty	Description	Notes
58046901	58046901	0	DECAL	
58046902	58046902	0	DECAL	
58046903	58046903	0	DECAL	
58046909	58046909	0	DECAL	
58046910	58046910	0	DECAL	
58046912	58046912	0	DECAL	
58046913	58046913	0	DECAL	
58057676	58057676	0	DECAL	
58057678	58057678	0	DECAL	
58057698	58057698	0	DECAL	
58057712	58057712	0	DECAL	
58057722	58057722	0	DECAL	
58057724	58057724	0	DECAL	
58057732	58057732	0	DECAL	



580.57698

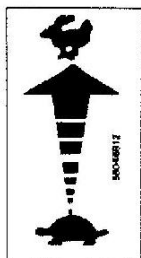

580.46912



580.46913



580.57772 ★

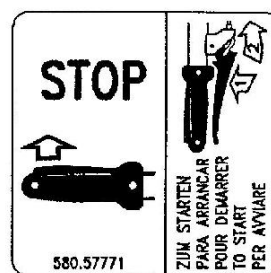

580.57771 ★



580.57767 ★

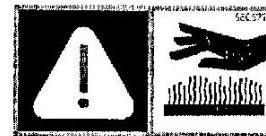

580.57768 ★



580.57678



580.57712



580.57676

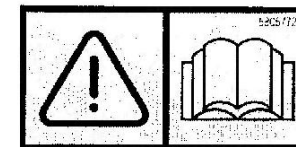

580.57724



580.57770 ★



580.57722

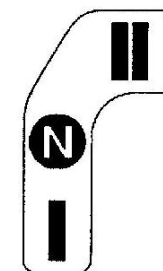

580.57732

FERRARI

500 serie 95

ADESIVI

STICKERS
ADHESIVOS

AUTOCOLLANTS
AUFKLEBES

DALLA MACCHINA
DE LA MAQUINA
DE LA MACHINE
FROM THE MACHINE
AB DER MASCHINE

AGGIORNAMENTO

REVISION

MISE A JOUR

APLAZAMIENTO

ANPASSUNG

13

Rev.
1

12/2003

★N

ZENNE

Pos.	Code	Q.ty	Description	Notes
58046912	58046912	0	DECAL	
58046913	58046913	0	DECAL	
58057676	58057676	0	DECAL	
58057678	58057678	0	DECAL	
58057698	58057698	0	DECAL	
58057712	58057712	0	DECAL	
58057722	58057722	0	DECAL	
58057724	58057724	0	DECAL	
58057732	58057732	0	DECAL	
58057767	58057767	0	DECAL	
58057768	58057768	0	DECAL	
58057770	58057770	0	DECAL	
58057771	58057771	0	DECAL	
58057772	58057772	0	DECAL	

SPARE PARTS INSTANCE INDEX





SPARE PARTS INSTANCE INDEX

Code	Parts Table	Pos.	Q.ty	Code	Parts Table	Pos.	Q.ty	Code	Parts Table	Pos.	Q.ty
30000628	001_1_12621	30000628	0	31111097	008_4_13416	31111097	0	31112151	003_0_12805	31112151	0
	001_2_12649	30000628	0	31111151	001_1_12621	31111151	0		003_1_12834	31112151	0
30010120	007_2_13157	30010120	0		001_2_12649	31111151	0		003_2_12864	31112151	0
	007_3_13177	30010120	0		001_3_12676	31111151	0		011_3_13744	31112151	0
30010142	009_0_13470	30010142	0		001_4_12698	31111151	0	31112152	006_0_13060	31112152	0
	009_1_13502	30010142	0	31111165	008_0_13197	31111165	0		006_1_13089	31112152	0
30040001	003_0_12805	30040001	0	31111216	009_0_13470	31111216	0	31112153	007_0_13116	31112153	0
	003_1_12834	30040001	0		009_1_13502	31111216	0		007_1_13140	31112153	0
	003_2_12864	30040001	0	31111217	007_0_13116	31111217	0		007_2_13157	31112153	0
30040050	007_0_13116	30040050	0	31111229	007_0_13116	31111229	0		007_3_13177	31112153	0
	007_1_13140	30040050	0		007_1_13140	31111229	0		008_0_13197	31112153	0
31100003	002_2_12761	31100003	0		007_2_13157	31111229	0		008_1_13255	31112153	0
	002_3_12779	31100003	0		007_3_13177	31111229	0		008_2_13308	31112153	0
31100015	002_0_12722	31100015	0	31112089	008_0_13197	31112089	0		008_3_13362	31112153	0
	002_1_12741	31100015	0		008_1_13255	31112089	0		008_4_13416	31112153	0
	002_3_12779	31100015	0		008_2_13308	31112089	0	31112154	001_1_12621	31112154	0
31100786	002_0_12722	31100786	0		008_3_13362	31112089	0		001_2_12649	31112154	0
	002_1_12741	31100786	0		008_4_13416	31112089	0		001_3_12676	31112154	0
	002_2_12761	31100786	0		010_0_13623	31112089	0		001_4_12698	31112154	0
	002_3_12779	31100786	0		010_1_13645	31112089	0	31112211	004_0_12893	31112211	0
31111086	008_0_13197	31111086	0	31112090	010_0_13623	31112090	0		004_1_12930	31112211	0
	008_1_13255	31111086	0		010_1_13645	31112090	0		004_2_12967	31112211	0
	008_2_13308	31111086	0	31112092	008_0_13197	31112092	0		007_0_13116	31112211	0
	008_3_13362	31111086	0		008_1_13255	31112092	0		007_1_13140	31112211	0
	008_4_13416	31111086	0		008_2_13308	31112092	0		007_2_13157	31112211	0
31111090	001_1_12621	31111090	0		008_3_13362	31112092	0		007_3_13177	31112211	0
	001_2_12649	31111090	0		008_4_13416	31112092	0	31112213	001_1_12621	31112213	0
	003_0_12805	31111090	0		010_0_13623	31112092	0		001_2_12649	31112213	0
	003_1_12834	31111090	0		010_1_13645	31112092	0		001_3_12676	31112213	0
	003_2_12864	31111090	0	31112149	011_3_13744	31112149	0		001_4_12698	31112213	0
31111097	008_0_13197	31111097	0	31112150	001_1_12621	31112150	0	31112219	011_3_13744	31112219	0
	008_1_13255	31111097	0		001_2_12649	31112150	0	31112295	007_2_13157	31112295	0
	008_2_13308	31111097	0		001_3_12676	31112150	0		007_3_13177	31112295	0
	008_3_13362	31111097	0		001_4_12698	31112150	0	31121007	001_2_12649	31121007	0



SPARE PARTS INSTANCE INDEX

Code	Parts Table	Pos.	Q.ty	Code	Parts Table	Pos.	Q.ty	Code	Parts Table	Pos.	Q.ty
31121007	001_3_12676	31121007	0	31241060	008_1_13255	31241060	0	31241100	001_1_12621	31241100	0
	001_4_12698	31121007	0		008_2_13308	31241060	0		001_2_12649	31241100	0
31152085	010_0_13623	31152085	0		008_3_13362	31241060	0		001_3_12676	31241100	0
	010_1_13645	31152085	0		008_4_13416	31241060	0		001_4_12698	31241100	0
31152103	003_0_12805	31152103	0		010_0_13623	31241060	0		007_0_13116	31241100	0
	003_1_12834	31152103	0		010_1_13645	31241060	0		007_1_13140	31241100	0
	003_2_12864	31152103	0	31241061	008_0_13197	31241061	0		007_2_13157	31241100	0
31211040	008_0_13197	31211040	0		008_1_13255	31241061	0		007_3_13177	31241100	0
	008_1_13255	31211040	0		008_2_13308	31241061	0		009_0_13470	31241100	0
	008_2_13308	31211040	0		008_3_13362	31241061	0		009_1_13502	31241100	0
	008_3_13362	31211040	0		008_4_13416	31241061	0		011_3_13744	31241100	0
	008_4_13416	31211040	0	31241080	001_1_12621	31241080	0	31241120	011_3_13744	31241120	0
31211080	001_1_12621	31211080	0		001_2_12649	31241080	0	31241121	007_2_13157	31241121	0
	002_0_12722	31211080	0		001_3_12676	31241080	0		007_3_13177	31241121	0
	002_1_12741	31211080	0		001_4_12698	31241080	0	31312080	006_0_13060	31312080	0
	002_2_12761	31211080	0		003_0_12805	31241080	0		006_1_13089	31312080	0
	002_3_12779	31211080	0		003_1_12834	31241080	0	31312082	003_0_12805	31312082	0
	007_0_13116	31211080	0		003_2_12864	31241080	0		003_1_12834	31312082	0
	007_1_13140	31211080	0		006_0_13060	31241080	0		003_2_12864	31312082	0
	007_2_13157	31211080	0		006_1_13089	31241080	0		009_0_13470	31312082	0
	008_0_13197	31211080	0		007_0_13116	31241080	0		009_1_13502	31312082	0
	008_1_13255	31211080	0		007_1_13140	31241080	0		009_2_13534	31312082	0
	008_2_13308	31211080	0		007_2_13157	31241080	0		009_3_13564	31312082	0
	008_3_13362	31211080	0		007_3_13177	31241080	0		009_4_13594	31312082	0
	008_4_13416	31211080	0		011_3_13744	31241080	0	31312083	002_1_12741	31312083	0
	010_0_13623	31211080	0	31241085	003_0_12805	31241085	0		002_2_12761	31312083	0
	010_1_13645	31211080	0		003_1_12834	31241085	0		002_3_12779	31312083	0
31211100	006_0_13060	31211100	0		003_2_12864	31241085	0	31312084	003_0_12805	31312084	0
	006_1_13089	31211100	0		007_0_13116	31241085	0		003_1_12834	31312084	0
	011_3_13744	31211100	0		009_0_13470	31241085	0		003_2_12864	31312084	0
31221121	003_0_12805	31221121	0		009_1_13502	31241085	0	31312085	003_1_12834	31312085	0
	003_1_12834	31221121	0		009_2_13534	31241085	0	31312088	002_0_12722	31312088	0
	003_2_12864	31221121	0		009_3_13564	31241085	0		002_1_12741	31312088	0
31241060	008_0_13197	31241060	0		009_4_13594	31241085	0		002_2_12761	31312088	0



SPARE PARTS INSTANCE INDEX

Code	Parts Table	Pos.	Q.ty	Code	Parts Table	Pos.	Q.ty	Code	Parts Table	Pos.	Q.ty
31312088	002_3_12779	31312088	0	31411084	008_4_13416	31411084	0	31422064	010_1_13645	31422064	0
31312094	003_0_12805	31312094	0	31411104	001_1_12621	31411104	0	31423043	008_0_13197	31423043	0
	003_1_12834	31312094	0		001_2_12649	31411104	0		008_1_13255	31423043	0
	003_2_12864	31312094	0		001_3_12676	31411104	0		008_2_13308	31423043	0
31312102	006_0_13060	31312102	0		001_4_12698	31411104	0		008_3_13362	31423043	0
	006_1_13089	31312102	0		009_0_13470	31411104	0		008_4_13416	31423043	0
31312103	011_3_13744	31312103	0		009_1_13502	31411104	0	31423084	001_1_12621	31423084	0
31312124	003_0_12805	31312124	0		009_2_13534	31411104	0		001_2_12649	31423084	0
	003_1_12834	31312124	0		009_3_13564	31411104	0		001_3_12676	31423084	0
	003_2_12864	31312124	0		009_4_13594	31411104	0		001_4_12698	31423084	0
31312125	003_0_12805	31312125	0	31411105	009_0_13470	31411105	0		002_0_12722	31423084	0
	003_1_12834	31312125	0		009_1_13502	31411105	0		002_1_12741	31423084	0
	003_2_12864	31312125	0	31421083	001_1_12621	31421083	0		002_2_12761	31423084	0
31411043	008_0_13197	31411043	0		001_2_12649	31421083	0		002_3_12779	31423084	0
	008_1_13255	31411043	0		001_3_12676	31421083	0		003_0_12805	31423084	0
	008_2_13308	31411043	0		001_4_12698	31421083	0		003_1_12834	31423084	0
	008_3_13362	31411043	0		003_0_12805	31421083	0		003_2_12864	31423084	0
	008_4_13416	31411043	0		003_1_12834	31421083	0		006_0_13060	31423084	0
31411064	001_1_12621	31411064	0		003_2_12864	31421083	0		006_1_13089	31423084	0
	001_2_12649	31411064	0		009_0_13470	31421083	0		007_0_13116	31423084	0
	008_1_13255	31411064	0		009_1_13502	31421083	0		007_1_13140	31423084	0
	008_2_13308	31411064	0		009_2_13534	31421083	0		007_2_13157	31423084	0
	008_3_13362	31411064	0		009_3_13564	31421083	0		007_3_13177	31423084	0
	008_4_13416	31411064	0		009_4_13594	31421083	0		008_0_13197	31423084	0
31411084	001_1_12621	31411084	0	31421101	004_0_12893	31421101	0		008_1_13255	31423084	0
	001_2_12649	31411084	0		004_1_12930	31421101	0		008_2_13308	31423084	0
	001_3_12676	31411084	0		004_2_12967	31421101	0		008_3_13362	31423084	0
	001_4_12698	31411084	0		011_3_13744	31421101	0		008_4_13416	31423084	0
	006_0_13060	31411084	0	31421132	003_1_12834	31421132	0		011_3_13744	31423084	0
	006_1_13089	31411084	0		003_2_12864	31421132	0	31423105	002_0_12722	31423105	0
	008_0_13197	31411084	0	31422064	003_0_12805	31422064	0		002_1_12741	31423105	0
	008_1_13255	31411084	0		003_1_12834	31422064	0		002_3_12779	31423105	0
	008_2_13308	31411084	0		003_2_12864	31422064	0		006_0_13060	31423105	0
	008_3_13362	31411084	0		010_0_13623	31422064	0		006_1_13089	31423105	0



SPARE PARTS INSTANCE INDEX

Code	Parts Table	Pos.	Q.ty	Code	Parts Table	Pos.	Q.ty	Code	Parts Table	Pos.	Q.ty
31423105	009_0_13470	31423105	0	34213060	004_2_12967	34213060	0	37112173	002_3_12779	37112173	0
	009_1_13502	31423105	0	34213061	004_0_12893	34213061	0	37112229	004_0_12893	37112229	0
	011_3_13744	31423105	0		004_1_12930	34213061	0		004_1_12930	37112229	0
31423130	003_0_12805	31423130	0		004_2_12967	34213061	0		004_2_12967	37112229	0
	007_2_13157	31423130	0	35111047	006_0_13060	35111047	0	37112231	002_2_12761	37112231	0
	007_3_13177	31423130	0		006_1_13089	35111047	0		002_3_12779	37112231	0
	011_3_13744	31423130	0	35111053	004_0_12893	35111053	0	37112233	002_0_12722	37112233	0
34110020	008_3_13362	34110020	0		004_1_12930	35111053	0		002_1_12741	37112233	0
	008_4_13416	34110020	0		004_2_12967	35111053	0		002_3_12779	37112233	0
34110028	009_0_13470	34110028	0	35111055	004_0_12893	35111055	0	37320120	004_0_12893	37320120	0
	009_1_13502	34110028	0		004_1_12930	35111055	0		004_1_12930	37320120	0
	009_2_13534	34110028	0		004_2_12967	35111055	0		004_2_12967	37320120	0
	009_3_13564	34110028	0	35121031	004_0_12893	35121031	0	37910832	004_0_12893	37910832	0
	009_4_13594	34110028	0		004_1_12930	35121031	0		004_1_12930	37910832	0
34211029	009_0_13470	34211029	0		004_2_12967	35121031	0		004_2_12967	37910832	0
	009_1_13502	34211029	0	35211120	004_0_12893	35211120	0	37911532	009_0_13470	37911532	0
	009_2_13534	34211029	0		004_1_12930	35211120	0		009_1_13502	37911532	0
	009_3_13564	34211029	0		004_2_12967	35211120	0		009_2_13534	37911532	0
	009_4_13594	34211029	0	37111150	004_0_12893	37111150	0		009_3_13564	37911532	0
34211042	004_0_12893	34211042	0		004_1_12930	37111150	0		009_4_13594	37911532	0
	004_1_12930	34211042	0		004_2_12967	37111150	0	38111400	006_0_13060	38111400	0
	004_2_12967	34211042	0	37111152	004_0_12893	37111152	0		006_1_13089	38111400	0
34213020	008_0_13197	34213020	0		004_1_12930	37111152	0	38211400	009_0_13470	38211400	0
	008_1_13255	34213020	0		004_2_12967	37111152	0		009_1_13502	38211400	0
	008_2_13308	34213020	0	37111202	006_0_13060	37111202	0		009_2_13534	38211400	0
	008_3_13362	34213020	0		006_1_13089	37111202	0		009_3_13564	38211400	0
	008_4_13416	34213020	0	37111250	004_0_12893	37111250	0		009_4_13594	38211400	0
	009_0_13470	34213020	0		004_1_12930	37111250	0	38211500	003_0_12805	38211500	0
	009_1_13502	34213020	0		004_2_12967	37111250	0		003_1_12834	38211500	0
	009_2_13534	34213020	0	37111253	006_0_13060	37111253	0		003_2_12864	38211500	0
	009_3_13564	34213020	0		006_1_13089	37111253	0	38213002	006_0_13060	38213002	0
	009_4_13594	34213020	0	37112173	002_0_12722	37112173	0		006_1_13089	38213002	0
34213060	004_0_12893	34213060	0		002_1_12741	37112173	0	38213800	004_0_12893	38213800	0
	004_1_12930	34213060	0		002_2_12761	37112173	0		004_1_12930	38213800	0



SPARE PARTS INSTANCE INDEX

Code	Parts Table	Pos.	Q.ty	Code	Parts Table	Pos.	Q.ty	Code	Parts Table	Pos.	Q.ty
38213800	004_2_12967	38213800	0	52456340	004_2_12967	52456340	0	53152412	003_2_12864	53152412	0
39113501	011_3_13744	39113501	0	52456344	004_0_12893	52456344	0	53156150	002_3_12779	53156150	0
39113502	011_3_13744	39113502	0		004_1_12930	52456344	0	53156326	003_0_12805	53156326	0
39114008	011_3_13744	39114008	0	52456349	004_2_12967	52456349	0	53156327	003_0_12805	53156327	0
39114010	011_3_13744	39114010	0	52456354	004_0_12893	52456354	0		003_1_12834	53156327	0
39115010	011_3_13744	39115010	0		004_1_12930	52456354	0		003_2_12864	53156327	0
39413502	011_3_13744	39413502	0		004_2_12967	52456354	0	53156332	003_0_12805	53156332	0
39414008	011_3_13744	39414008	0	52456359	004_0_12893	52456359	0	53243851	006_0_13060	53243851	0
39414010	011_3_13744	39414010	0	52456360	004_1_12930	52456360	0		006_1_13089	53243851	0
39415010	011_3_13744	39415010	0		004_2_12967	52456360	0	53247468	002_2_12761	53247468	0
50947833	002_0_12722	50947833	0	52456362	004_0_12893	52456362	0	53247488	002_3_12779	53247488	0
	002_1_12741	50947833	0		004_1_12930	52456362	0	55102678	003_0_12805	55102678	0
	002_2_12761	50947833	0		004_2_12967	52456362	0		003_1_12834	55102678	0
	002_3_12779	50947833	0	52456370	004_0_12893	52456370	0		003_2_12864	55102678	0
52357250	009_0_13470	52357250	0		004_1_12930	52456370	0	55102714	007_0_13116	55102714	0
	009_1_13502	52357250	0		004_2_12967	52456370	0		007_1_13140	55102714	0
	009_2_13534	52357250	0	52456389	004_0_12893	52456389	0		007_2_13157	55102714	0
	009_3_13564	52357250	0		004_1_12930	52456389	0		007_3_13177	55102714	0
	009_4_13594	52357250	0		004_2_12967	52456389	0	55142076	009_0_13470	55142076	0
52443852	006_0_13060	52443852	0	52456390	004_0_12893	52456390	0		009_1_13502	55142076	0
	006_1_13089	52443852	0		004_1_12930	52456390	0		009_2_13534	55142076	0
52443853	006_0_13060	52443853	0		004_2_12967	52456390	0		009_3_13564	55142076	0
	006_1_13089	52443853	0	53143712	011_3_13744	53143712	0		009_4_13594	55142076	0
52447896	002_0_12722	52447896	0	53143875	003_0_12805	53143875	0	55147842	002_0_12722	55147842	0
	002_1_12741	52447896	0	53143879	003_0_12805	53143879	0		002_1_12741	55147842	0
	002_2_12761	52447896	0	53147482	002_0_12722	53147482	0		002_2_12761	55147842	0
	002_3_12779	52447896	0		002_1_12741	53147482	0		002_3_12779	55147842	0
52448182	006_0_13060	52448182	0	53152401	003_1_12834	53152401	0	55220363	007_0_13116	55220363	0
	006_1_13089	52448182	0		003_2_12864	53152401	0		007_1_13140	55220363	0
52456336	004_0_12893	52456336	0	53152402	003_1_12834	53152402	0		007_2_13157	55220363	0
	004_1_12930	52456336	0		003_2_12864	53152402	0		007_3_13177	55220363	0
	004_2_12967	52456336	0	53152411	003_1_12834	53152411	0	55242528	009_0_13470	55242528	0
52456340	004_0_12893	52456340	0		003_2_12864	53152411	0		009_1_13502	55242528	0
	004_1_12930	52456340	0	53152412	003_1_12834	53152412	0		009_2_13534	55242528	0



SPARE PARTS INSTANCE INDEX

Code	Parts Table	Pos.	Q.ty	Code	Parts Table	Pos.	Q.ty	Code	Parts Table	Pos.	Q.ty
55242528	009_3_13564	55242528	0	56120364	007_3_13177	56120364	0	56148218	010_1_13645	56148218	0
	009_4_13594	55242528	0	56143360	009_0_13470	56143360	0	56148285	008_0_13197	56148285	0
55243340	007_0_13116	55243340	0	56143865	006_0_13060	56143865	0		008_1_13255	56148285	0
	007_1_13140	55243340	0		006_1_13089	56143865	0		008_2_13308	56148285	0
	007_2_13157	55243340	0	56143880	006_0_13060	56143880	0		008_3_13362	56148285	0
	007_3_13177	55243340	0		006_1_13089	56143880	0		008_4_13416	56148285	0
	008_0_13197	55243340	0	56143883	006_0_13060	56143883	0	56148286	008_0_13197	56148286	0
55248038	008_0_13197	55248038	0		006_1_13089	56143883	0	56148287	008_0_13197	56148287	0
	008_1_13255	55248038	0	56147499	001_1_12621	56147499	0		008_1_13255	56148287	0
	008_2_13308	55248038	0		001_2_12649	56147499	0		008_2_13308	56148287	0
	008_3_13362	55248038	0	56147520	003_0_12805	56147520	0		008_3_13362	56148287	0
	008_4_13416	55248038	0	56147655	008_0_13197	56147655	0		008_4_13416	56148287	0
55248041	008_0_13197	55248041	0		008_1_13255	56147655	0	56148470	010_0_13623	56148470	0
	008_1_13255	55248041	0		008_2_13308	56147655	0		010_1_13645	56148470	0
	008_2_13308	55248041	0		008_3_13362	56147655	0	56149655	009_0_13470	56149655	0
	008_3_13362	55248041	0		008_4_13416	56147655	0		009_1_13502	56149655	0
	008_4_13416	55248041	0	56147711	008_0_13197	56147711	0		009_2_13534	56149655	0
55248283	008_0_13197	55248283	0		008_1_13255	56147711	0		009_3_13564	56149655	0
	008_1_13255	55248283	0		008_2_13308	56147711	0		009_4_13594	56149655	0
	008_2_13308	55248283	0		008_3_13362	56147711	0	56150361	008_0_13197	56150361	0
	008_3_13362	55248283	0		008_4_13416	56147711	0		008_1_13255	56150361	0
	008_4_13416	55248283	0	56147845	002_0_12722	56147845	0		008_2_13308	56150361	0
55248284	008_0_13197	55248284	0		002_1_12741	56147845	0		008_3_13362	56150361	0
	008_1_13255	55248284	0		002_2_12761	56147845	0		008_4_13416	56150361	0
	008_2_13308	55248284	0		002_3_12779	56147845	0		010_0_13623	56150361	0
	008_3_13362	55248284	0	56147923	003_0_12805	56147923	0		010_1_13645	56150361	0
	008_4_13416	55248284	0		003_1_12834	56147923	0	56152241	001_2_12649	56152241	0
55252316	001_1_12621	55252316	0		003_2_12864	56147923	0		001_3_12676	56152241	0
	001_2_12649	55252316	0	56148037	008_0_13197	56148037	0		001_4_12698	56152241	0
	001_3_12676	55252316	0		008_1_13255	56148037	0	56152300	007_0_13116	56152300	0
	001_4_12698	55252316	0		008_2_13308	56148037	0	56152314	009_0_13470	56152314	0
56120364	007_0_13116	56120364	0		008_3_13362	56148037	0	56152403	003_1_12834	56152403	0
	007_1_13140	56120364	0		008_4_13416	56148037	0		003_2_12864	56152403	0
	007_2_13157	56120364	0	56148218	010_0_13623	56148218	0	56156119	001_4_12698	56156119	0



SPARE PARTS INSTANCE INDEX

Code	Parts Table	Pos.	Q.ty	Code	Parts Table	Pos.	Q.ty	Code	Parts Table	Pos.	Q.ty
56156152	001_1_12621	56156152	0	56157353	009_4_13594	56157353	0	56456351	004_2_12967	56456351	0
	001_2_12649	56156152	0	56347484	002_0_12722	56347484	0	56456477	004_2_12967	56456477	0
56156940	007_0_13116	56156940	0		002_1_12741	56347484	0	56456478	004_0_12893	56456478	0
	007_1_13140	56156940	0		002_3_12779	56347484	0		004_1_12930	56456478	0
	007_2_13157	56156940	0	56349782	002_0_12722	56349782	0		004_2_12967	56456478	0
	007_3_13177	56156940	0		002_1_12741	56349782	0	58002429	006_0_13060	58002429	0
56156948	007_3_13177	56156948	0		002_3_12779	56349782	0		008_0_13197	58002429	0
56157235	009_0_13470	56157235	0	56356165	002_3_12779	56356165	0		008_1_13255	58002429	0
	009_1_13502	56157235	0	56356251	002_2_12761	56356251	0		008_2_13308	58002429	0
	009_2_13534	56157235	0		002_3_12779	56356251	0		008_3_13362	58002429	0
	009_3_13564	56157235	0	56356328	004_0_12893	56356328	0		008_4_13416	58002429	0
	009_4_13594	56157235	0		004_1_12930	56356328	0	58002538	008_0_13197	58002538	0
56157244	009_0_13470	56157244	0		004_2_12967	56356328	0		008_1_13255	58002538	0
	009_1_13502	56157244	0	56356329	004_0_12893	56356329	0		008_2_13308	58002538	0
	009_2_13534	56157244	0		004_1_12930	56356329	0		008_3_13362	58002538	0
	009_3_13564	56157244	0		004_2_12967	56356329	0		008_4_13416	58002538	0
	009_4_13594	56157244	0	56356330	004_0_12893	56356330	0	58026222	008_0_13197	58026222	0
56157246	009_0_13470	56157246	0		004_1_12930	56356330	0		008_1_13255	58026222	0
	009_1_13502	56157246	0		004_2_12967	56356330	0		008_2_13308	58026222	0
	009_2_13534	56157246	0	56356331	004_0_12893	56356331	0		008_3_13362	58026222	0
	009_3_13564	56157246	0		004_1_12930	56356331	0		008_4_13416	58026222	0
	009_4_13594	56157246	0		004_2_12967	56356331	0	58026224	008_0_13197	58026224	0
56157256	009_0_13470	56157256	0	56356348	004_2_12967	56356348	0	58042167	006_0_13060	58042167	0
	009_1_13502	56157256	0	56359553	011_3_13744	56359553	0		008_0_13197	58042167	0
	009_2_13534	56157256	0	56359554	011_3_13744	56359554	0		008_1_13255	58042167	0
	009_3_13564	56157256	0	56443857	006_0_13060	56443857	0		008_2_13308	58042167	0
	009_4_13594	56157256	0		006_1_13089	56443857	0		008_3_13362	58042167	0
56157307	009_2_13534	56157307	0	56443871	006_0_13060	56443871	0		008_4_13416	58042167	0
	009_3_13564	56157307	0		006_1_13089	56443871	0	58042200	010_0_13623	58042200	0
	009_4_13594	56157307	0	56456347	004_0_12893	56456347	0		010_1_13645	58042200	0
56157332	008_1_13255	56157332	0		004_1_12930	56456347	0	58042202	008_0_13197	58042202	0
	008_2_13308	56157332	0		004_2_12967	56456347	0		008_1_13255	58042202	0
	008_3_13362	56157332	0	56456351	004_0_12893	56456351	0		008_2_13308	58042202	0
	008_4_13416	56157332	0		004_1_12930	56456351	0		008_3_13362	58042202	0



SPARE PARTS INSTANCE INDEX

Code	Parts Table	Pos.	Q.ty	Code	Parts Table	Pos.	Q.ty	Code	Parts Table	Pos.	Q.ty
58042202	008_4_13416	58042202	0	58046902	013_0_13845	58046902	0	58048009	008_2_13308	58048009	0
	010_0_13623	58042202	0	58046903	012_0_13785	58046903	0		008_3_13362	58048009	0
	010_1_13645	58042202	0		013_0_13845	58046903	0		008_4_13416	58048009	0
58043053	003_0_12805	58043053	0	58046909	012_0_13785	58046909	0	58048025	008_0_13197	58048025	0
	003_1_12834	58043053	0		013_0_13845	58046909	0	58048214	010_0_13623	58048214	0
	003_2_12864	58043053	0	58046910	012_0_13785	58046910	0		010_1_13645	58048214	0
58043086	004_0_12893	58043086	0		013_0_13845	58046910	0	58048215	010_0_13623	58048215	0
	004_1_12930	58043086	0	58046912	012_0_13785	58046912	0		010_1_13645	58048215	0
	004_2_12967	58043086	0		013_0_13845	58046912	0	58048301	008_0_13197	58048301	0
58043117	003_0_12805	58043117	0		013_1_13860	58046912	0		010_1_13645	58048301	0
	003_1_12834	58043117	0	58046913	012_0_13785	58046913	0	58050345	008_0_13197	58050345	0
	003_2_12864	58043117	0		013_0_13845	58046913	0		008_1_13255	58050345	0
58043176	009_0_13470	58043176	0		013_1_13860	58046913	0		008_2_13308	58050345	0
	009_1_13502	58043176	0	58047649	010_0_13623	58047649	0		008_3_13362	58050345	0
	009_2_13534	58043176	0		010_1_13645	58047649	0		010_0_13623	58050345	0
	009_3_13564	58043176	0	58047712	008_0_13197	58047712	0		010_1_13645	58050345	0
	009_4_13594	58043176	0		008_1_13255	58047712	0	58051670	008_0_13197	58051670	0
58043223	008_0_13197	58043223	0		008_2_13308	58047712	0		008_1_13255	58051670	0
	008_1_13255	58043223	0		008_3_13362	58047712	0		008_2_13308	58051670	0
	008_2_13308	58043223	0		008_4_13416	58047712	0		008_3_13362	58051670	0
	008_3_13362	58043223	0	58048000	008_0_13197	58048000	0		008_4_13416	58051670	0
	008_4_13416	58043223	0		008_1_13255	58048000	0	58052018	012_0_13785	58052018	0
58043242	008_0_13197	58043242	0		008_2_13308	58048000	0		012_1_13807	58052018	0
58043253	008_0_13197	58043253	0		008_3_13362	58048000	0		012_2_13824	58052018	0
58043391	008_0_13197	58043391	0		008_4_13416	58048000	0	58052019	012_0_13785	58052019	0
58043855	006_0_13060	58043855	0	58048002	008_0_13197	58048002	0		012_1_13807	58052019	0
	006_1_13089	58043855	0		008_1_13255	58048002	0		012_2_13824	58052019	0
58043874	006_0_13060	58043874	0		008_2_13308	58048002	0	58052020	012_0_13785	58052020	0
	006_1_13089	58043874	0	58048005	008_1_13255	58048005	0		012_1_13807	58052020	0
58043881	006_0_13060	58043881	0		008_2_13308	58048005	0		012_2_13824	58052020	0
	006_1_13089	58043881	0		008_3_13362	58048005	0	58052021	012_0_13785	58052021	0
58046901	012_0_13785	58046901	0		008_4_13416	58048005	0		012_1_13807	58052021	0
	013_0_13845	58046901	0	58048009	008_0_13197	58048009	0		012_2_13824	58052021	0
58046902	012_0_13785	58046902	0		008_1_13255	58048009	0	58052022	012_0_13785	58052022	0



SPARE PARTS INSTANCE INDEX

Code	Parts Table	Pos.	Q.ty	Code	Parts Table	Pos.	Q.ty	Code	Parts Table	Pos.	Q.ty
58052022	012_1_13807	58052022	0	58052302	010_0_13623	58052302	0	58057289	008_4_13416	58057289	0
	012_2_13824	58052022	0	58052304	008_0_13197	58052304	0	58057292	008_0_13197	58057292	0
58052023	012_0_13785	58052023	0		008_1_13255	58052304	0	58057293	008_1_13255	58057293	0
	012_1_13807	58052023	0		008_2_13308	58052304	0		008_2_13308	58057293	0
	012_2_13824	58052023	0		008_3_13362	58052304	0	58057294	008_1_13255	58057294	0
58052024	012_0_13785	58052024	0	58052309	007_0_13116	58052309	0		008_2_13308	58057294	0
	012_1_13807	58052024	0	58052325	011_3_13744	58052325	0		008_3_13362	58057294	0
	012_2_13824	58052024	0	58052326	011_3_13744	58052326	0		008_4_13416	58057294	0
58052029	012_1_13807	58052029	0	58052327	011_3_13744	58052327	0	58057295	008_0_13197	58057295	0
	012_2_13824	58052029	0	58056391	004_0_12893	58056391	0		008_1_13255	58057295	0
58052033	012_0_13785	58052033	0		004_1_12930	58056391	0		008_2_13308	58057295	0
	012_1_13807	58052033	0		004_2_12967	58056391	0		008_3_13362	58057295	0
	012_2_13824	58052033	0	58056593	008_4_13416	58056593	0		008_4_13416	58057295	0
58052034	012_0_13785	58052034	0	58056942	007_0_13116	58056942	0	58057302	008_0_13197	58057302	0
	012_1_13807	58052034	0		007_1_13140	58056942	0		008_1_13255	58057302	0
	012_2_13824	58052034	0		007_2_13157	58056942	0		008_2_13308	58057302	0
58052144	012_1_13807	58052144	0		007_3_13177	58056942	0		008_3_13362	58057302	0
	012_2_13824	58052144	0	58056991	001_3_12676	58056991	0		008_4_13416	58057302	0
58052145	012_1_13807	58052145	0		001_4_12698	58056991	0	58057306	008_1_13255	58057306	0
	012_2_13824	58052145	0	58057247	009_0_13470	58057247	0		008_2_13308	58057306	0
58052146	012_1_13807	58052146	0		009_1_13502	58057247	0		008_3_13362	58057306	0
	012_2_13824	58052146	0		009_2_13534	58057247	0		008_4_13416	58057306	0
58052147	012_1_13807	58052147	0		009_3_13564	58057247	0	58057333	008_1_13255	58057333	0
	012_2_13824	58052147	0		009_4_13594	58057247	0		008_2_13308	58057333	0
58052148	012_1_13807	58052148	0	58057263	008_0_13197	58057263	0		008_3_13362	58057333	0
	012_2_13824	58052148	0		008_1_13255	58057263	0		008_4_13416	58057333	0
58052149	012_1_13807	58052149	0		008_2_13308	58057263	0	58057334	008_1_13255	58057334	0
	012_2_13824	58052149	0		008_3_13362	58057263	0		008_2_13308	58057334	0
58052150	012_2_13824	58052150	0		008_4_13416	58057263	0		008_3_13362	58057334	0
58052151	012_2_13824	58052151	0	58057288	008_0_13197	58057288	0		008_4_13416	58057334	0
58052154	012_2_13824	58052154	0	58057289	008_0_13197	58057289	0	58057385	001_4_12698	58057385	0
58052155	012_2_13824	58052155	0		008_1_13255	58057289	0	58057402	008_4_13416	58057402	0
58052274	011_3_13744	58052274	0		008_2_13308	58057289	0	58057676	013_0_13845	58057676	0
58052301	008_0_13197	58052301	0		008_3_13362	58057289	0		013_1_13860	58057676	0



SPARE PARTS INSTANCE INDEX

Code	Parts Table	Pos.	Q.ty	Code	Parts Table	Pos.	Q.ty	Code	Parts Table	Pos.	Q.ty
58057678	012_0_13785	58057678	0	58150313	010_1_13645	58150313	0	59056051	001_2_12649	59056051	0
	013_0_13845	58057678	0	58157346	008_3_13362	58157346	0		001_3_12676	59056051	0
	013_1_13860	58057678	0		008_4_13416	58157346	0		001_4_12698	59056051	0
58057698	009_1_13502	58057698	0	59015425	003_0_12805	59015425	0	59056052	001_1_12621	59056052	0
	009_2_13534	58057698	0		003_1_12834	59015425	0		001_2_12649	59056052	0
	009_3_13564	58057698	0		003_2_12864	59015425	0	59056089	001_3_12676	59056089	0
	012_0_13785	58057698	0	59047450	001_1_12621	59047450	0		001_4_12698	59056089	0
	013_0_13845	58057698	0		001_2_12649	59047450	0	59056111	001_3_12676	59056111	0
	013_1_13860	58057698	0		001_3_12676	59047450	0		001_4_12698	59056111	0
58057712	012_0_13785	58057712	0		001_4_12698	59047450	0	59056365	004_0_12893	59056365	0
	013_0_13845	58057712	0	59047454	001_1_12621	59047454	0		004_1_12930	59056365	0
	013_1_13860	58057712	0		001_2_12649	59047454	0		004_2_12967	59056365	0
58057714	009_1_13502	58057714	0		001_3_12676	59047454	0	59056383	004_1_12930	59056383	0
	009_2_13534	58057714	0	59047709	008_0_13197	59047709	0		004_2_12967	59056383	0
	009_3_13564	58057714	0		008_1_13255	59047709	0	59056385	004_0_12893	59056385	0
58057722	012_0_13785	58057722	0		008_2_13308	59047709	0	59056925	007_0_13116	59056925	0
	013_0_13845	58057722	0		008_3_13362	59047709	0		007_1_13140	59056925	0
	013_1_13860	58057722	0		008_4_13416	59047709	0	59056935	007_0_13116	59056935	0
58057724	012_0_13785	58057724	0	59047743	011_3_13744	59047743	0		007_1_13140	59056935	0
	013_0_13845	58057724	0	59047745	011_3_13744	59047745	0		007_2_13157	59056935	0
	013_1_13860	58057724	0	59047927	001_1_12621	59047927	0		007_3_13177	59056935	0
58057732	013_0_13845	58057732	0		001_2_12649	59047927	0	59056945	009_0_13470	59056945	0
	013_1_13860	58057732	0		001_3_12676	59047927	0		009_1_13502	59056945	0
58057767	013_1_13860	58057767	0		001_4_12698	59047927	0	59056975	009_2_13534	59056975	0
58057768	013_1_13860	58057768	0	59048200	010_0_13623	59048200	0		009_3_13564	59056975	0
58057770	013_1_13860	58057770	0		010_1_13645	59048200	0		009_4_13594	59056975	0
58057771	013_1_13860	58057771	0	59048208	010_0_13623	59048208	0	59056980	007_2_13157	59056980	0
58057772	013_1_13860	58057772	0		010_1_13645	59048208	0		007_3_13177	59056980	0
58150313	008_0_13197	58150313	0	59048469	010_0_13623	59048469	0	59056982	001_2_12649	59056982	0
	008_1_13255	58150313	0		010_1_13645	59048469	0		001_3_12676	59056982	0
	008_2_13308	58150313	0	59048522	009_0_13470	59048522	0		001_4_12698	59056982	0
	008_3_13362	58150313	0		009_1_13502	59048522	0	59056984	001_2_12649	59056984	0
	008_4_13416	58150313	0	59052204	008_0_13197	59052204	0	59056986	001_2_12649	59056986	0
	010_0_13623	58150313	0	59056051	001_1_12621	59056051	0		001_4_12698	59056986	0

SPARE PARTS INSTANCE INDEX

Code	Parts Table	Pos.	Q.ty	Code	Parts Table	Pos.	Q.ty
59056989	009_2_13534	59056989	0	59057579	001_1_12621	59057579	0
	009_3_13564	59056989	0	59057580	001_1_12621	59057580	0
	009_4_13594	59056989	0	59059551	011_3_13744	59059551	0
59057075	008_0_13197	59057075	0	59059561	011_3_13744	59059561	0
59057076	008_2_13308	59057076	0	59059571	011_3_13744	59059571	0
	008_3_13362	59057076	0	59247884	002_0_12722	59247884	0
	008_4_13416	59057076	0		002_1_12741	59247884	0
59057077	008_1_13255	59057077	0		002_2_12761	59247884	0
	008_2_13308	59057077	0		002_3_12779	59247884	0
	008_3_13362	59057077	0	59247970	002_0_12722	59247970	0
	008_4_13416	59057077	0		002_1_12741	59247970	0
59057240	009_0_13470	59057240	0	59247971	002_0_12722	59247971	0
	009_1_13502	59057240	0		002_1_12741	59247971	0
	009_2_13534	59057240	0		002_2_12761	59247971	0
	009_3_13564	59057240	0		002_3_12779	59247971	0
	009_4_13594	59057240	0	59248490	006_0_13060	59248490	0
59057252	009_0_13470	59057252	0		006_1_13089	59248490	0
	009_1_13502	59057252	0	59256252	002_2_12761	59256252	0
	009_2_13534	59057252	0	59256257	002_3_12779	59256257	0
	009_3_13564	59057252	0	59256265	002_3_12779	59256265	0
	009_4_13594	59057252	0	59259555	011_3_13744	59259555	0
59057270	009_1_13502	59057270	0	59259563	011_3_13744	59259563	0
	009_2_13534	59057270	0	59259567	011_3_13744	59259567	0
	009_3_13564	59057270	0	59259578	011_3_13744	59259578	0
	009_4_13594	59057270	0	59259580	011_3_13744	59259580	0
59057308	009_2_13534	59057308	0	862791000	007_0_13116	862791000	0
	009_3_13564	59057308	0	92243685	011_3_13744	92243685	0
	009_4_13594	59057308	0	92457794	011_3_13744	92457794	0
59057309	009_2_13534	59057309	0	F0305017160	009_0_13470	F0305017	0
	009_3_13564	59057309	0	F0843818000	007_0_13116	F0843818	0
	009_4_13594	59057309	0	F0862791000	007_0_13116	F0862791	0
59057561	001_1_12621	59057561	0				
59057575	001_1_12621	59057575	0				
59057576	001_1_12621	59057576	0				